

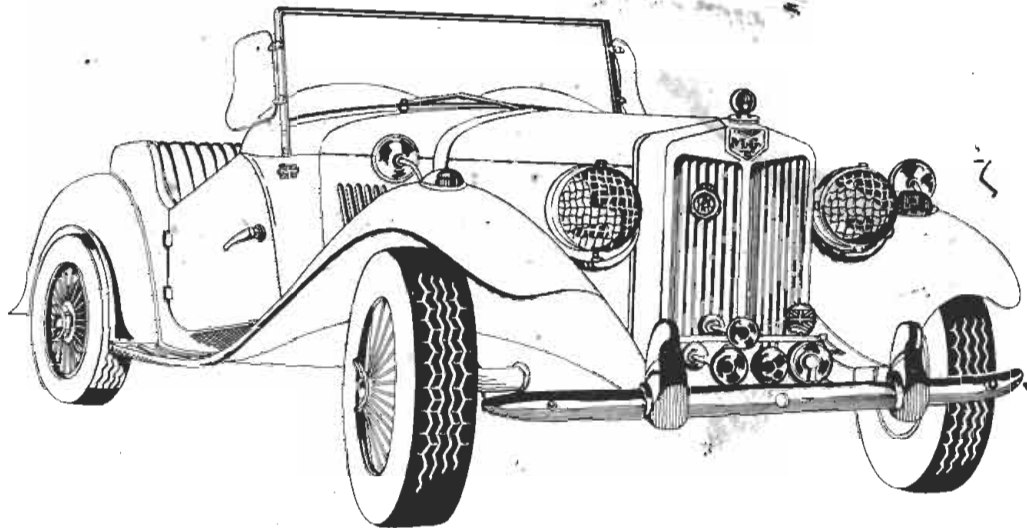

FIBERFAB INC.

ASSEMBLY MANUAL



World's Oldest and Largest Manufacturer of Fiberglass Sports Car Bodies

As part of Fiberfab's continuing effort to improve our products and to better serve our customers, we are in the process of publishing a completely revised MiGi II Assembly Manual. Our kit has changed a great deal since the publication of our first assembly manual, and we hope to facilitate the construction of the MiGi II with new instructions and diagrams. However, as the new edition of the Assembly Manual is not yet completed, the Addendum is intended to provide updated information to our customers in the interim.

The construction of the MiGi II is broken down into three stages: the assembly of the body, the preparation of the Volkswagen chassis, and the joining of the body to the chassis. The chassis may be prepared before beginning the body or during construction. However, the chassis must be complete by Operation 31.*

Please read over the contents of the Addendum as you use the Assembly Manual. By familiarizing yourself with the parts, the nomenclature, and the Shop Suggestions, you will be better able to build your MiGi II easily and enjoyably.

If you have any questions or problems during assembly, our Customer Service Department is standing by ready to help. Simply call (408) 263-4050, and we'll be happy to assist you.

We are sure you will enjoy every minute of owning your MiGi II, from each stage of construction to years of driving pleasure.

PLEASE NOTE OUR NEW CUSTOMER SERVICE TOLL-FREE TELEPHONE NUMBERS:

1-800-538-7758 and 1-800-538-7759

Required Tools and Materials

Electric Drill

Drill Bits: complete set ranging from 1/8" - 1"

Soldering gun

Solder

Sabre saw - fine toothed

File

Hole saws: 1", 2", 3"

Pop rivet gun

Pen knife

Screwdrivers: 1 large and 1 small standard
1 large and 1 small phillips

Wrenches: complete set open-ended

Scribe

Scissors

Wire cutter

Wire crimpers

Electric Tape

Sand Paper: 80, 120, 360, 400, 800

1/8" metal tubing - 3" long

Hammer

Extra electric wire and connections

Recommended Tools and Materials:

C-clamps

Socket set

Rubber mallett

Rubber cement

Shop Practices and Suggestions

1. The MiGi II body can be most easily constructed if the main body section is resting on saw horses. This will facilitate access to all areas of the body, and keep the fiberglass off the floor where it can be chipped or scratched.
2. The MiGi II body is prescribed at almost all bolt points and finished edges. In drilling over prescribed bolt holes, tap a small nail into the prescribed mark to locate a positioning hole for the drill bit. This will prevent the bit from sliding off of the prescribed mark.
3. Most drill sizes throughout the instructions are one size larger than the bolt to be used. This allows for some adjustment and positioning when the fiberglass parts are joined. Once the bolts are tightened, there will not be any play in the bolts or in the joints they attach.
4. In trimming to the prescribed lines, use a hack saw or electric saw and trim to within 1/8" of the prescribed line. Then use a file to trim the remaining 1/8" to the line. The saw can chip the fiberglass, and the 1/8" allows a "margin" for this chipping.
5. When filing fiberglass, always file from the finished side toward the unfinished side. Pulling the file outward against the finished edge can chip or crack the gelcoated edge.
6. Use only a fine-toothed blade on the sabre saw for all fiberglass cutting. A large-toothed blade will chip the fiberglass or gelcoat finish.
7. It is helpful to line the guide edge of the sabre saw with masking tape, to prevent this edge from chipping or scratching the fiberglass while working.
8. When using C-clamps to hold fiberglass pieces onto a working surface or to attach two pieces together, place a soft cloth between the clamp and the finished side of the fiberglass. This will prevent scratching or cracking the fiberglass by the C-clamp.

FIBERGLASS CARE AND REPAIR

Fiberfab uses the finest materials available in making our fiberglass bodies. Much of our fiberglass is hand laid, rather than heat injected, which increases its resistance to shattering and cracking. We use only the highest quality fibers, and our fiberglass is similar in strength, thickness and durability to that used for boat hulls. With proper care your Fiberfab body should last for years, and retain all of its original beauty.

Most car paints become faded in color and dull in finish after a few years as the paint oxidizes with age. Fiberglass is coated with gelcoat, which does not oxidize. Therefore it will always retain its present vibrant color and sheen. If you wish to obtain a glossier finish, use any normal car wax or polish, and buff lightly. The wax will not harm the gelcoat finish. There are also many good protective coatings for fiberglass available commercially, which will help to discourage surface scratches, and allow for easy cleaning. Fiberglass can be washed with any commercial car cleaner or detergent.

Fiberglass does not dent on impact: it cracks. Therefore, never pull or pound on the fiberglass as the stress can result in cracking or tearing. Most minor cracks, gelcoat chips, and scratches can be repaired at home with very inexpensive materials.

To correct surface scratches or chips, mix a small amount of gelcoat and resin as directed on the gelcoat repair kit, included with the MiGi. Dab the mixture over the scratch or chip with a finger or paint brush. Allow the surface to dry 3 to 4 hours, and cover the gelcoated area with a commercial car wax, to aid in "curing" the gelcoat. Allow the surface to dry for 24 hours. Wet sand the repaired surface using 400 grade sand paper, and finish wet sanding using 600 grade sand paper. Smooth the surface with a light rubbing compound, and buff the entire area using any commercial car wax.

Cracks usually weaken the fiberglass, even if the crack does not appear to break both sides of the fiberglass. To properly repair a crack and restore the strength of the fiberglass, use fiberglass body filler

mixed with resin. Both items are available at most body repair centers or fiberglass boat shops. Mix the filler with resin, and press the mixture to the unfinished side of the fiberglass at the point of the crack, in a line 1" to 2" wide. Allow the surface to dry thoroughly, at least three hours, before repairing the finished side.

At the line of the crack, grind a "V" into the finished side of the fiberglass over the crack. Fill the V-crack with body filler (putty) available at hardware stores. Allow the putty to dry at least two hours. Dry sand the surface using 80 grade sand paper, and finish with 180 sand paper. Gelcoat the surface as instructed above.

Major tears or cracks in fiberglass are difficult to repair and should be handled professionally. Most body repair shops can repair fiberglass, or auto centers specializing in fiberglass car models.

FIBERGLASS COMPONENTS

The following illustrations and descriptions refer to the fiberglass components included in your MiGi II kit. Please familiarize yourself with the nomenclature used for it will be used throughout the manual and aid in helping you in the customer service department.

- A. (1) Main Body
- B. (2) Rear Fender
- C. (2) Running Boards
- D. (2) Front Fenders
- E. (2) Hood Sides
- F. (1) Hood
- G. (1) Grille Shell
- H. (1) Grilled Shell Inset
- I. (1) Battery Box
- J. (1) Gas Tank Bib
- K. (1) Dash Board
- L. (2) Seat Boxes
- M. (2) Doors
- N. (1) Engine Cover
- O. (1) Spare Tire
- P. (1) Rear Splash Panel

FIBERFAB PARTS DESCRIPTION FIG. 0.1

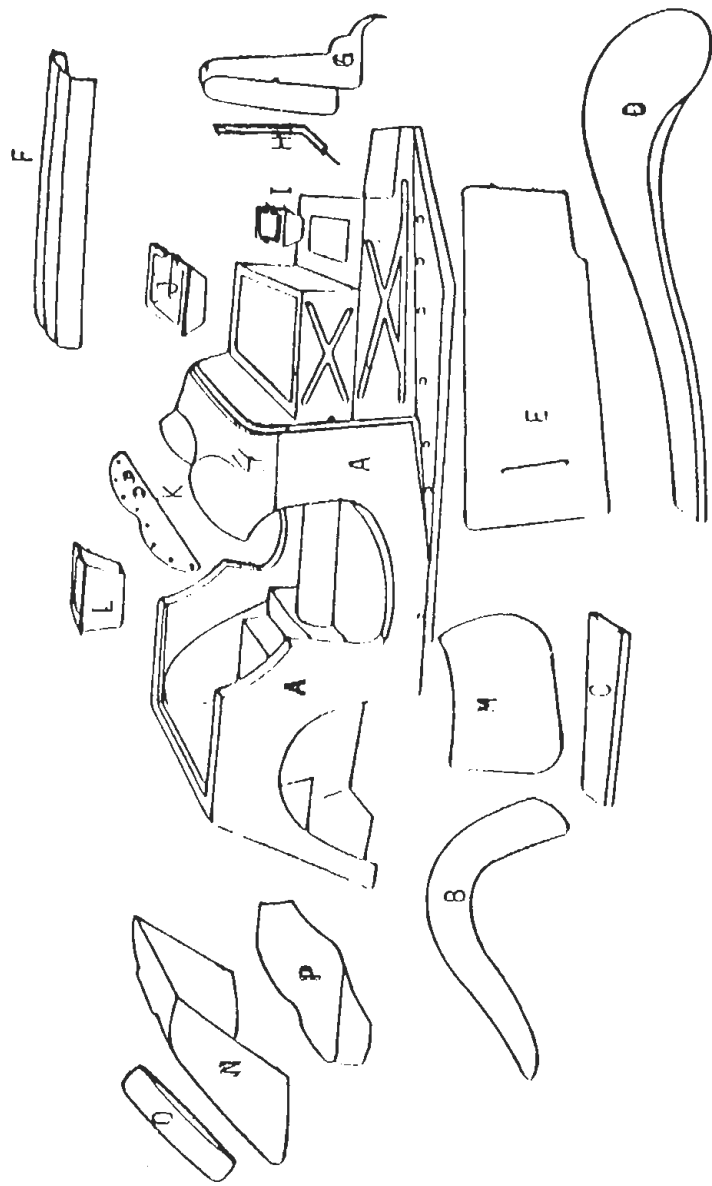



M559 Wheel Cover



M522 Convertible Top Kit



M542 Badge Bar



M527 Upholstery Kit



X161 Speedometer



*M530 Engine
Cover Holddown*



M531 Hood Hinges



M556 Cowl Strip



X164 Fuel Gauge

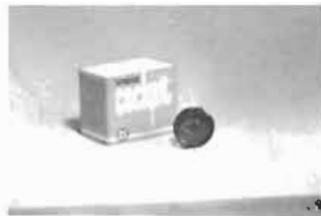

X165 Temperature Gauge



X163 Ammeter



X162 Tachometer



X187 Speedo Cable



X124 Air Cleaner



*M557 Fender
Separators*



*M532 Running
Board Trim*

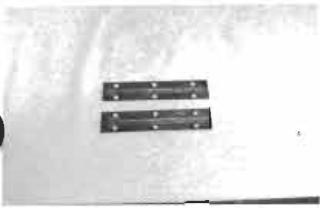

M563 Sea Cushion Hinge



MX196 Windshield Washer Kit



X144 License Plate Kit



X131 Dimmer



X144 License Plate Light



X131 Dimmer Switch



X122 Fog Light



M525 Fender Mirrors



X132 Ignition



MX197 Horn



MX192 Shifter Kit



X122 Cable Shortening Kit



M535 Radiator Cap



MX194 Contact Cement



X134, 135 Indicator Lights



X136 Headlight Switch

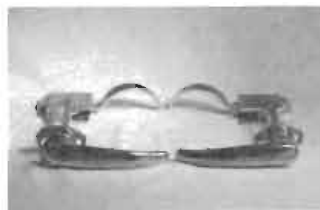

M514, M515 Door Handles & Latches

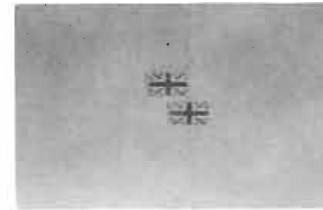

M544 Union Jacks



X130 Floor Pan Gasket



M550 Steering Wheel Adaptor Kit

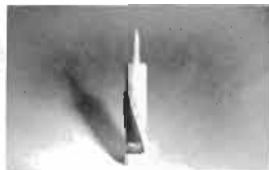

MX193 Silicone Seal



MX195 Undercoating



2001 AM/FM Stereo Auto Speaker



2004 Quartz Clock



MM553 Back Hinge



M519 Striker Plates



M558 Horn Button



MX199 Steering Column Bearing



M513 Fenderwelt



2016 Leather Belt



X141 Defroster Kit



X180 Heater Tubes



M522 Boot



M518 Gelcoat



M510 Door Hinges



M520 Headlight



M549 Steering Wheel



M534 Grille Louvers



M560 Wiring Kit



M517 Headlight Bracket



X128 Brake Kit



M562 Steering Extension



M523 "2" Bracket



M523 "S" Brackets Front & Rear



M555 Bolt Kit



M554 Engine Cover Hinge



M521 Wiper Kit



2015 Chrome Grill Shell



MIGI BOLT KIT

100	3/16" x 5/8" Pop Rivets
56	#8 x 1 $\frac{1}{4}$ " OH Phil. MS F/Washers
10	#10 Finishing Washers
65	#10 Washers
162	$\frac{1}{4}$ " Washers
48	5/16" Washers
18	3/8" Washers
32	$\frac{1}{4}$ " Fender Washers
12	5/16" Fender Washers
4	3/8" Fender Washers
2	3/8" Lock Washers
46	10-32 Nut Nylon
140	$\frac{1}{4}$ -20 Nut Nylon
44	5/16-18 Nut Nylon
12	3/8-18 Nut Nylon
4	5/16" Pal. Nut
66	$\frac{1}{4}$ -20 x 1 $\frac{1}{2}$ " Thruss HD Phillips M.S.
16	$\frac{1}{4}$ -20x1 $\frac{1}{2}$ " AHCS
46	10-32-1 $\frac{1}{2}$ " F.H.M.S.
56	$\frac{1}{4}$ -20-x1 $\frac{1}{2}$ " H.H.C.S.
2	$\frac{1}{4}$ -20-2 $\frac{1}{2}$ " H.H.C.S.
8	5/16-18x1 $\frac{1}{2}$ " H.H.C.S.
40	5/16-18x1 $\frac{1}{2}$ " Step Bolts
12	3/8-16x1 $\frac{1}{2}$ " H.H.C.S.
2	3/8-16x3" H.H.C.S.

LOCATION/PLACEMENT OF BOLTS

10) 3/8-18x1 1/2" HHCS 8) 3/8-18 Nut Nylon 14) 3/8" Washer 2) 3/8" Lock Washer 4) 3/8" Fender Washer	Rear Body Supports to Rear Fender and Main Body Flange
15) 3/16" x 5/8" Pop Rivets 15) #10 Washer	Fuel Tank Isolation Insert
8) 3/16" x 5/8" Pop Rivets	Battery Box Mounting
4) 3/16" x 5/8" Pop Rivets 4) #10 Washer	Original Brake Fluid Reservoir Mounting
4) 5/16"-18x1 1/2" HHCS 4) 5/16" Pal. Nut 4) 5/16" Fender Washer	Gas Tank Mounting
18) 1/4"-20x1 1/2" HHCS 18) 1/4"-20 Nut Nylon 36) 1/4" Washer	Rear Fender Mounting
16) 1/4"-20x1 1/2" HHCS 16) 1/4"-20 Nut Nylon 32) 1/4" Washer	Runningboard to main body, front and rear fenders
32) 5/16-18x 1 1/2" Step Bolts 32) 5/16-18 Nut Nylon 32) 5/16" Washer	Main Body to Pan
16) 1/4"-20x1 1/2" AHCS 16) 1/4"-20 Nut Nylon 16) 1/4" Washer	Door Hinges
8) 1/4"-20x1 1/2" Thruss HS Phillips MS 8) 1/4"-20 Nut Nylon 8) 1/4" Washer	Door Handle and Latch Inside
4) 10-32x 1 1/2" GHMS 4) 10-32 Nut Nylon 4) #10 Washer	Door Handle Outside
4) 1/4"-20x 1 1/2" Thruss HS Phillips MS 4) 1/4"-20 Nut Nylon 4) 1/4" Washer	Striker Plates
2) 3/8"-18x3" HHCS 2) 3/8-18 Nut Nylon 2) 3/8" Washer	Rear Bumper
2) 1/4"-20x2 1/2" HHCS 2) 1/4"-20 Nut Nylon 6) 1/4" Washer	Defroster Unit
10) 10-32 x 1 1/2" FHMS 10) 10-32 Nut Nylon 10) #10 Finishing Washers 10) #10 Washers	Dash Installation

LOCATION/PLACEMENT OF BOLTS(continued)

4) $\frac{1}{4}$ "-20x $1\frac{1}{2}$ " Thruss HD Phillips MS	Steering Clamp
4) $\frac{1}{4}$ "-20 Nut Nylon	
4) $\frac{1}{4}$ " Washers	
<hr/>	
12) $\frac{1}{4}$ "-20- $1\frac{1}{2}$ " Thruss HD Phillips MS	Hood Sides
12) $\frac{1}{4}$ "-20 Nut Nylon	
12) $\frac{1}{4}$ " Washers	
<hr/>	
18) 3/16" x 5/8" Pop Rivets	Secure Rubber Cowl Strip
<hr/>	
16) $\frac{1}{4}$ "-20 x $1\frac{1}{2}$ " HHCS	Front Fender to Main Body
16) $\frac{1}{4}$ "-20 Nut Nylon	
32) $\frac{1}{4}$ " Fender Washer	
<hr/>	
6) $\frac{1}{4}$ "-20 x $1\frac{1}{2}$ " Thruss HD Phillips MS	Front Grille to Front Fender
6) $\frac{1}{4}$ "-20 Nut Nylon	
6) $\frac{1}{4}$ " Washer	
<hr/>	
4) 5/16"-18 x $1\frac{1}{2}$ " HHCS	Steering Extension
4) 5/16-18 Nut Nylon	
8) 5/16" Washer	
<hr/>	
12) 10-32 x $1\frac{1}{2}$ " FHMS	Hood Hinges
12) 10-32 Nut Nylon	
12) #10 Washer	
<hr/>	
16) 10-32 x $1\frac{1}{2}$ " FHMS	Hood Latch
16) 10-32 Nut Nylon	Long for Bottom
16) #10 Washer	Half & Short For Upper Half
<hr/>	
4) $\frac{1}{4}$ "-20 x $1\frac{1}{2}$ " Thruss HD Phillips MS	Hood Chrome
4) $\frac{1}{4}$ "-20 Nut Nylon	
4) $\frac{1}{4}$ " Washers	
<hr/>	
4) $\frac{1}{4}$ "-20x $1\frac{1}{2}$ " Thruss HD Phillips MS	License Plate Bracket to Engine Cover
4) $\frac{1}{4}$ "-20 Nut Nylon	
4) $\frac{1}{4}$ " Washers	
<hr/>	
32) 3/16 x 5/8" Pop Rivets	Rear Deck Hinge
<hr/>	
4) $\frac{1}{4}$ "-20 x $1\frac{1}{2}$ " Thruss HD Phillips MS	Rear Splash Pan to Rear Brackets
4) $\frac{1}{4}$ "-20 Nut Nylon	
4) $\frac{1}{4}$ " Washers	
<hr/>	
8) $\frac{1}{4}$ "-20 x $1\frac{1}{2}$ " Thruss HD Phillips MS	Engine Cover Hold-Downs
8) $\frac{1}{4}$ "-20 Nut Nylon	
8) $\frac{1}{4}$ " Washers	
<hr/>	
6) $\frac{1}{4}$ "-20 x $1\frac{1}{2}$ " HHCS	Spare Tire Cover
6) $\frac{1}{4}$ "-20 Nut Nylon	
6) $\frac{1}{4}$ " Washer	
<hr/>	
12) $\frac{1}{4}$ "-20 x $1\frac{1}{2}$ " Thruss HD Phillips MS	Headlight Bracket Assembly
12) $\frac{1}{4}$ "-20 Nut Nylon	
12) $\frac{1}{4}$ " Washer	

LOCATION/PLACEMENT OF BOLTS(continued)

8) 5/16-18 x 1½" Step Bolts	Seat Box Mounting to Floor Pan
8) 5/16-18 Nut Nylon	
8) 5/16 Fender Washer	
<hr/>	
2) 3/8-18 x 1½" HHCS	Front Bumper Support to Main Body
2) 3/8-18 Nut Nylon	Section
2) 3/8" Washer	
<hr/>	
24) #8x1" OH Phil MS F/Washers	Door Panels to Door
<hr/>	
20) #8x1" OH Phil MS F/Washers	Side Upholstery Panels to Main Body
	Section
<hr/>	
12) #8x1" OH Phil MS F/Washers	Seat Back Hinge
<hr/>	
4) 10-32x 1½" FHMS	Badge Bar
4) 10-32 Nut Nylon	
4) #10 Washer	
<hr/>	
23) 3/16" x 5/8" Pop Rivets	Wiring Clamps

1. MAIN BODY PREPARATION

Fiberfab Parts Required:

M500 Main Body
Battery Box
MX196 Windshield Washer Kit
MX197 Horn

Tools And Materials Required:

Sabre Saw
File
Pop Rivet Gun
Screwdriver
Wrench
Scribe
Electric Drill
Drill Bits: 1/8", 13/64", 5/16", 1"

1. At the front of the main body, cut along the prescribed line to form holes for the gas tank, the battery box, and the steering column, as shown in Fig. 1.1.
2. Do not insert the gas tank pan at this time. Position the battery box in the lower cut out hole. Drill through the battery box rim and the main body at four corners, using a 13/64" drill bit. Pop rivet the battery box to the main body, using 3/16" x 5/8" pop rivets.
3. Drill a hole in the fire wall beneath and behind the gas tank pan hole at the passenger side. Use a 1" drill bit. The resulting hole will allow the wiring harness to pass to the front of the car. (Fig. 1.1)
4. Drill a hole in the outer, upper corner of the main body at the passenger side of the front wall, using a 5/16" drill bit. Drill one hole in each lower outer corner of the bottom front wall in the main body, using a 5/16" drill bit. These holes will also allow for passage of the wiring harness. (Fig. 1.1)
5. Position the bracket for the windshield washer kit on the wall below the gas tank hole, centered at the passenger side and approximately 1/2" from the top of the wall. Follow the instructions, Steps 1 and 2, included with the windshield washer kit, for mounting the water reservoir bag. (Fig. 1.2)
6. Position the horn along the front edge of the main body wall, next to the battery box. Scribe two bolt holes for attaching the horn. Drill out the holes using a 5/16" drill bit, and bolt the horn to the body. (Fig. 1.2)

MAIN BODY PREPARATION FIG. A1

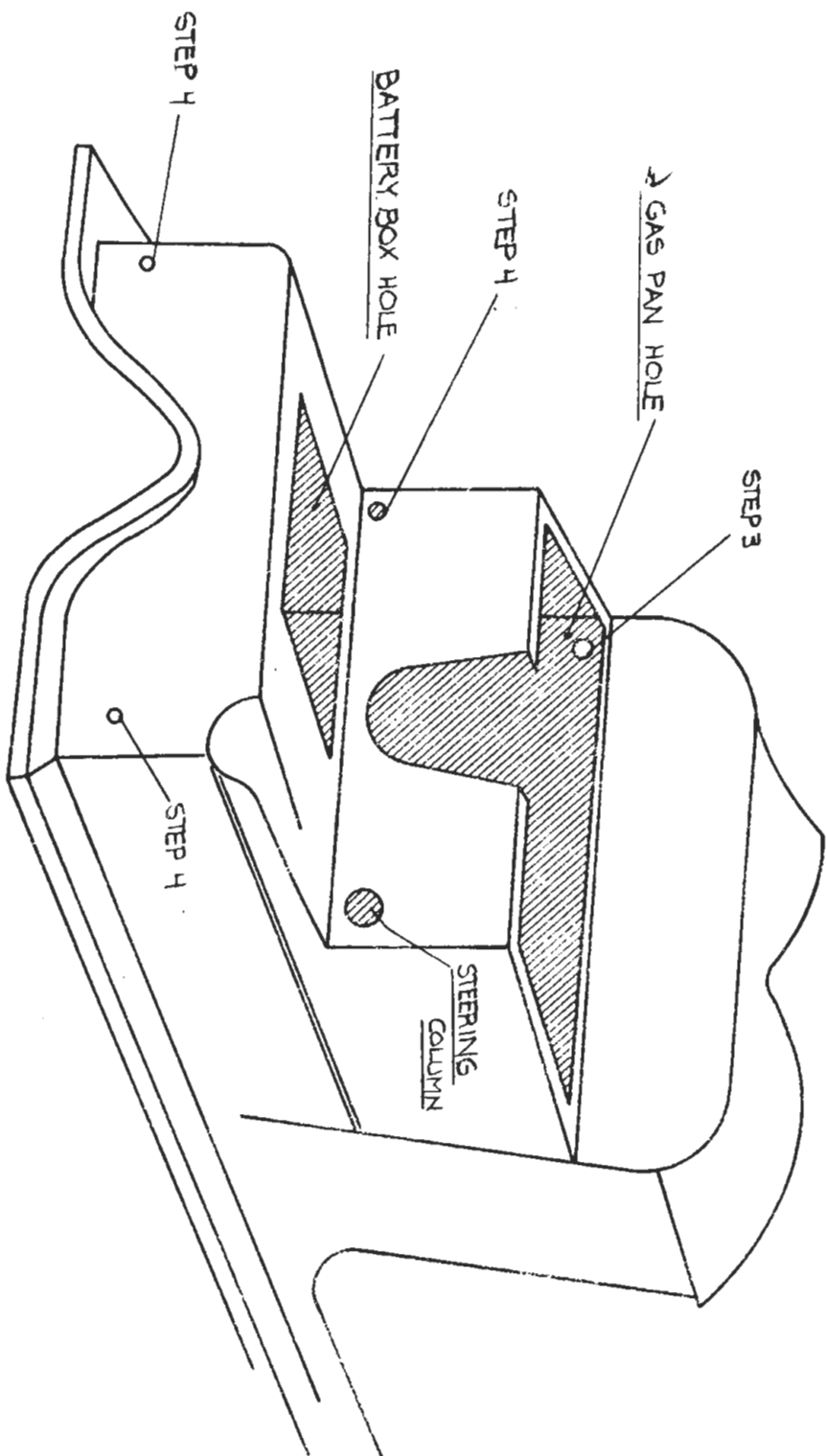

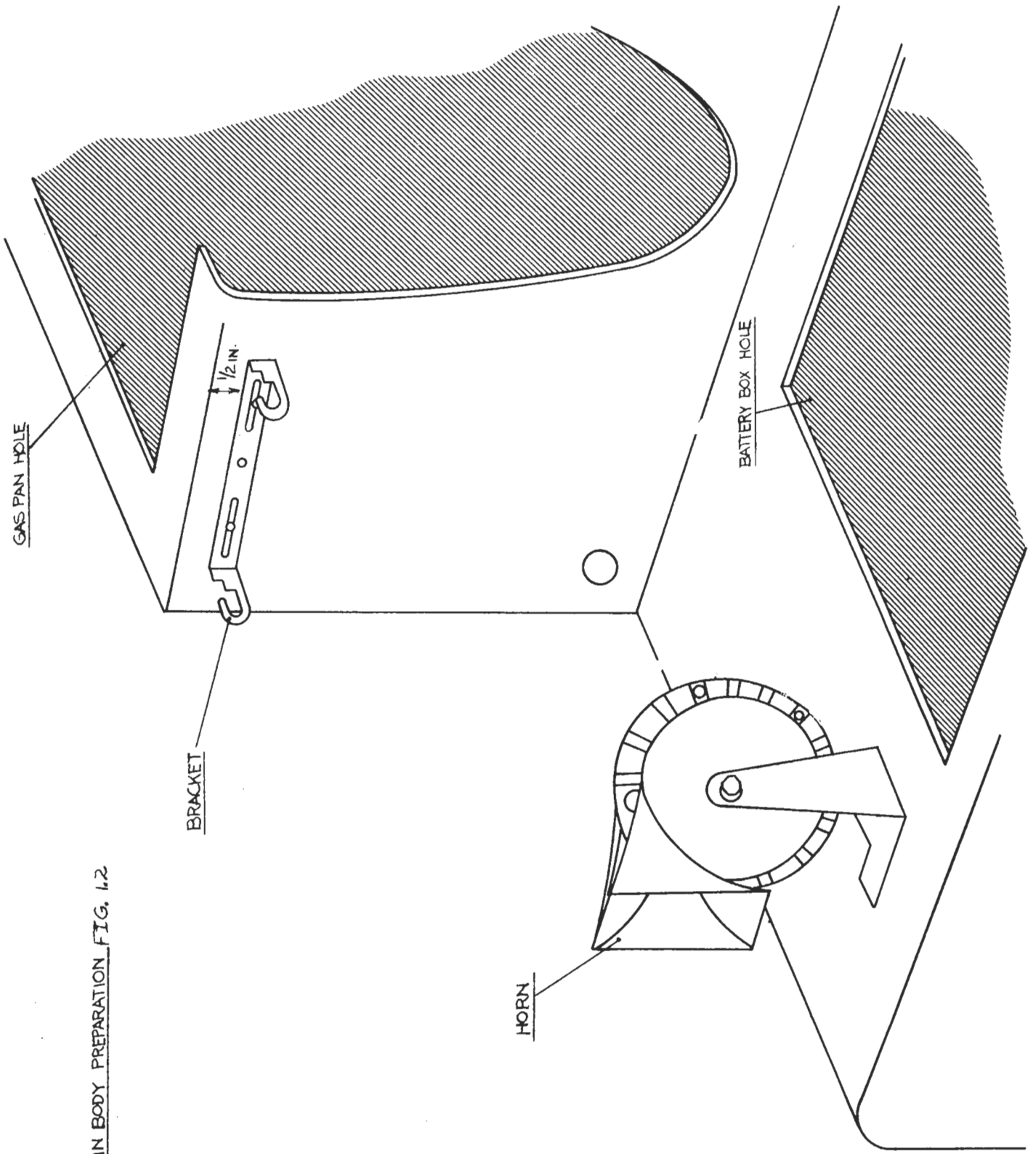

MAIN BODY PREPARATION FIG. 1.2

2. REAR FENDERS

Fiberfab Parts Required:

M500	Main Body Rear Fenders
M513	Fenderwelt
M555	Bolt Kit

Tools and Materials Required:

Sabre Saw
File
Wrench
Scissors
Electric Drill
Drill bit: 5/16"

1. Trim the outer curve of the fender to the prescribed line, and file smooth, as in Fig. 2.1 (Note: Read the note on trimming to scribes in "Shop Practices and Suggestions.")
2. Drill out the four prescribed holes in the main body, where the rear fender mounts. Use a 5/16" drill bit. (Fig. 2.2)
3. Drill out the four prescribed holes on the inner fender flange, and two on the front flange, where the fender meets the running boards. Use a 5/16" drill bit. (Fig. 2.2)
4. Attach the fender to the main body, matching prescribed drilled holes. Use $\frac{1}{4}$ " - 20 x $1\frac{1}{2}$ " washers and nylon nuts. Do not secure the bolts firmly. Tighten the nuts only to the point where they will hold the fender in place. There should be approximately $\frac{1}{4}$ " between fender and body.
5. Cut a piece of fenderwelt 54" long. Insert the fenderwelt between the fender and the main body. The fenderwelt will buckle at bolted points. Mark these points on the fenderwelt. (Fig. 2.1)
6. Remove the fenderwelt. Cut 1" rounded notches in the fenderwelt, to within $\frac{1}{4}$ " of the bead, at the points marked in Step 4. (Fig. 2.1)
7. Reinsert the fenderwelt between the fender and the body. Secure the nuts and bolts. While tightening each bolt, hold the fenderwelt in place. The bead of the fenderwelt should fit snugly against the fender and the body. Trim any excess fenderwelt at the bottom front edge of the fender.

MOUNTING REAR FENDER . FIG. 2.

FENDER WELT

1 in. NOTCHES

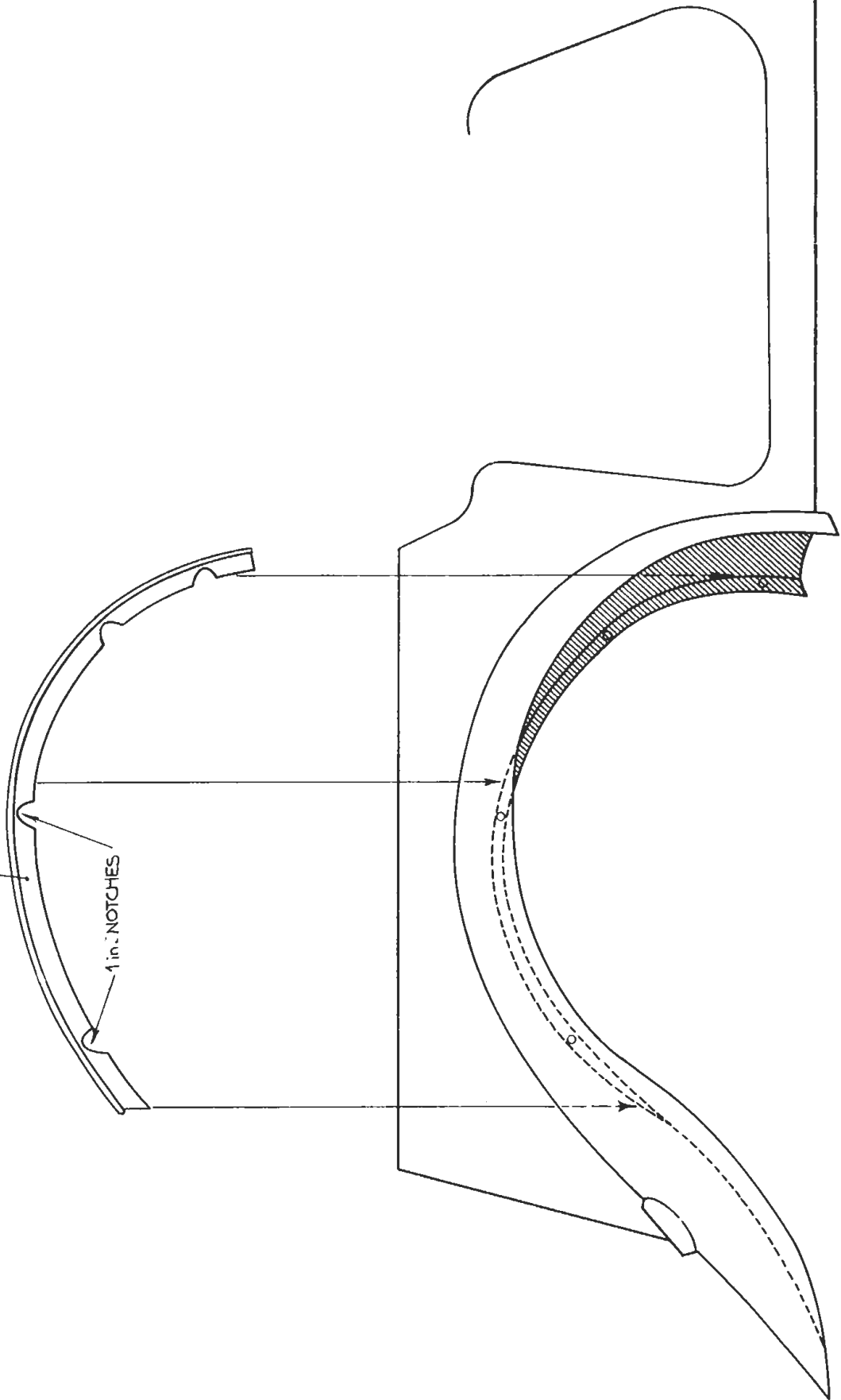

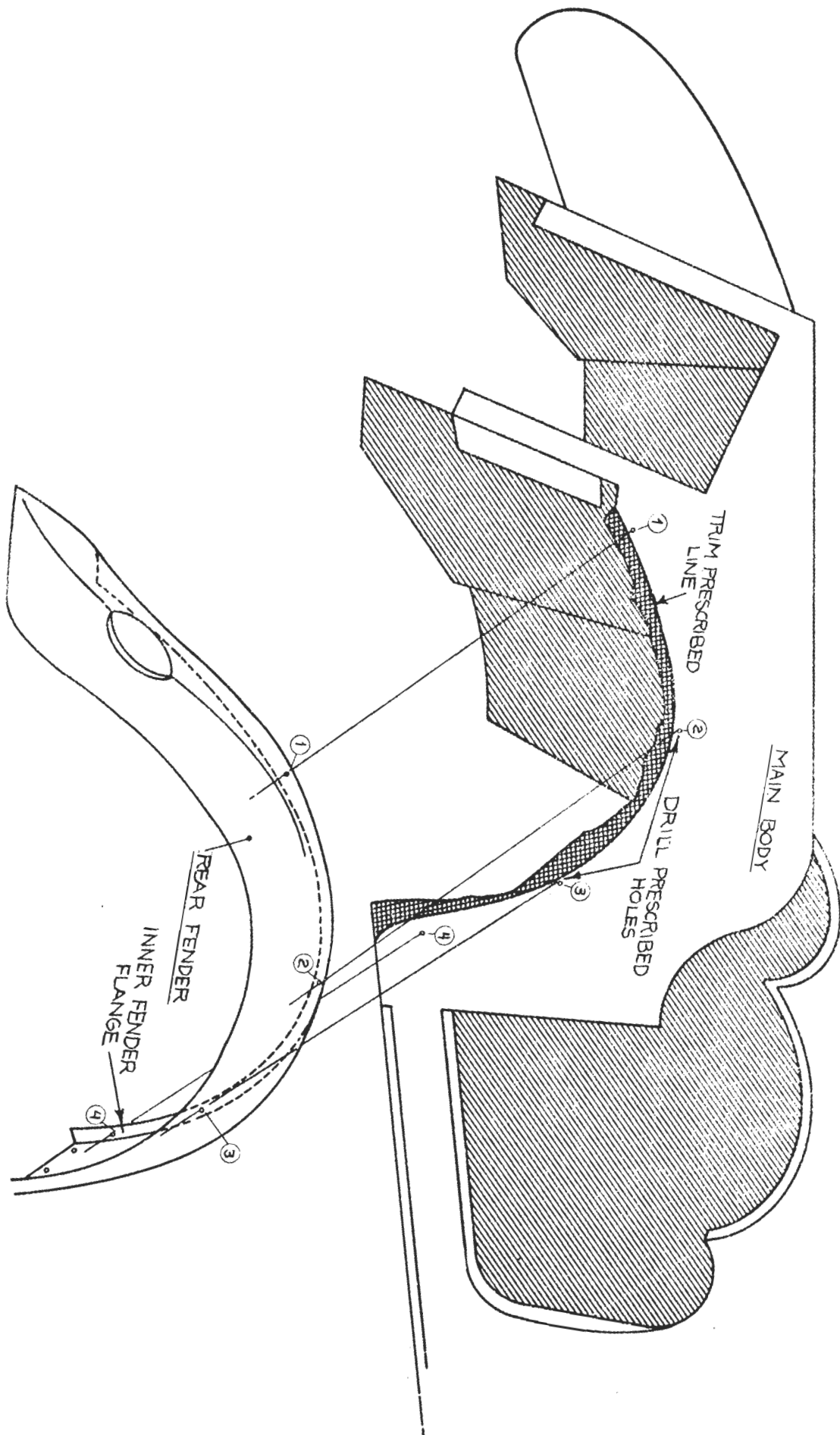

3. RUNNING BOARDS

Fiberfab Parts Required:

M500 Running Boards
M555 Bolt Kit

Tools and Materials Required:

Electric Drill
Drill Bit: 5/16"

1. Drill out the four prescribed holes in the main body, where the running board mounts. Use a 5/16" drill bit. (Fig. 3.1)
2. Drill out the four prescribed holes on the inner running board flange, two on the front flange and two on the rear flange, where the running board meets the front and rear fenders. Use a 5/16" drill bit.
3. Attach the running board to the main body, matching prescribed drilled bolt holes. Use $\frac{1}{4} \times 1\frac{1}{2}$ " bolts. Do not secure the bolts firmly. Tighten nuts only to the point where they will hold the running board in place. There should be approximately $\frac{1}{4}$ " between the running board and the main body. Do not attach the running board to the rear fender at this point. The running board will be permanently attached at a later step, when the front fenders are mounted.

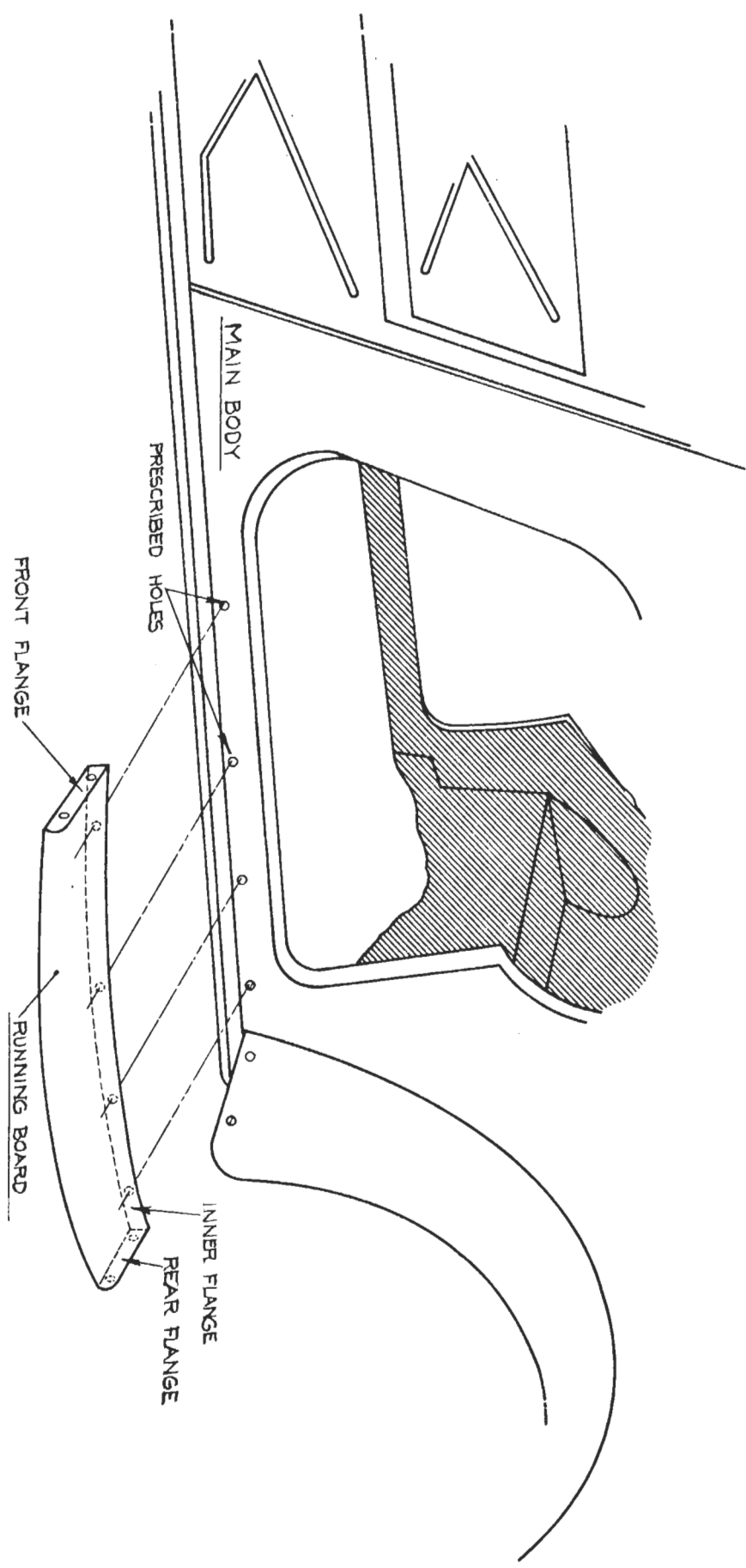

4. HOOD SIDES

Fiberfab Parts Required:

M500 Hood Sides
M555 Bolt Kit
M556 Cowl Strip

Tools and Materials Required:

Sabre Saw
File
Pop Rivet Gun
Wrench
Electric Drill
Drill bits: 13/64", 5/16"

1. Trim each hood side along the prescribed lines. (Note: The driver hood side has an extra prescribed hole for the steering column, and a slightly different pattern along the outer edges.) See Fig. 4.1. File edges smooth.
2. Drill out the prescribed holes at the side and bottom of each hood side. Use a 5/16" drill bit. (Fig. 4.1)
3. Drill out the prescribed holes in the main body, along the edge of the fire wall and at the bottom of each side. Use a 5/16" drill bit. (Fig. 4.2).
4. Attach the rubber cowl strip to the edge of the fire wall. Line up the head of the cowl with the top back edge of the fire wall. Beginning on the driver side of the car, drill through the cowl strip and the fire wall, using a 13/64" drill bit. Note: There are not prescribed holes for this operation. Do not drill directly next to the prescribed drilled holes (Step 3); allow approximately 1" on either side of these holes. Drill through the cowl strip and the fire wall every 6" to 8". Pop rivet the cowl strip to the fire wall using 3/16" pop rivets. There should be between 12 and 18 pop rivets attaching the cowl strip to the body. (Fig. 4.2)
5. Trim any excess cowl strip at the bottom edge of the fire wall. Locate the prescribed drilled holes beneath the cowl strip, by lightly running the tip of a drill bit along the cowl strip. The black rubber will "give" where there is a drill hole beneath. Drill at these points, using a 5/16" drill bit.
6. Bolt each hood side to the main body, along the fire wall edge only. Use 1/2" x 1 1/2" phillipshead bolts. Line up the prescribed drilled holes in the hood sides with those in the cowl strip and main body. When properly aligned, the top outer edge of the hood side should continue the line of the console at the side of the main body. (Fig. 4.3)

7. When both hood sides are attached, measure from the base of the main body to the top inside edge of each hood side. This measurement should be equal on both sides, in order for proper mounting of the grille shell.

ATTACHING HOOD SIDES - FIG 4,1

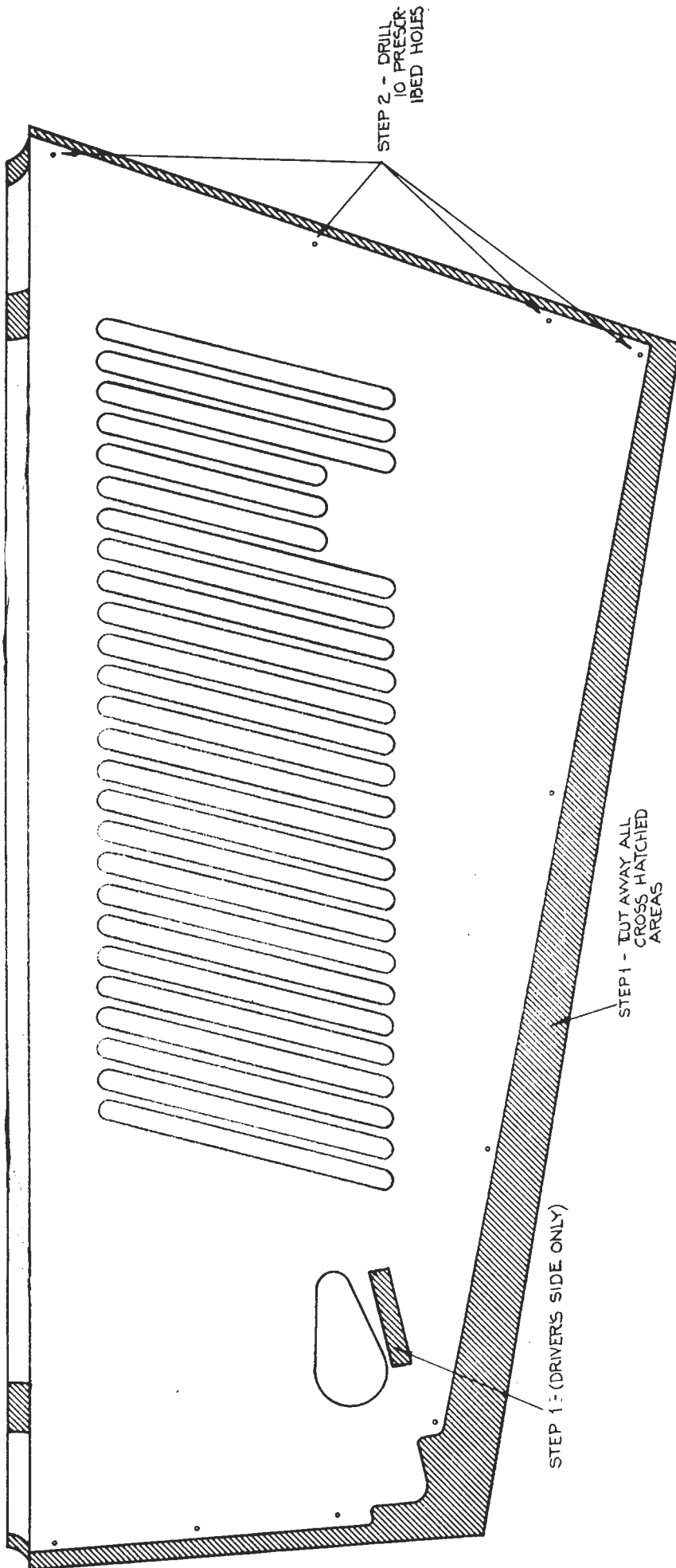

ATTACHING HOOD SIDES - FIG. 4.2

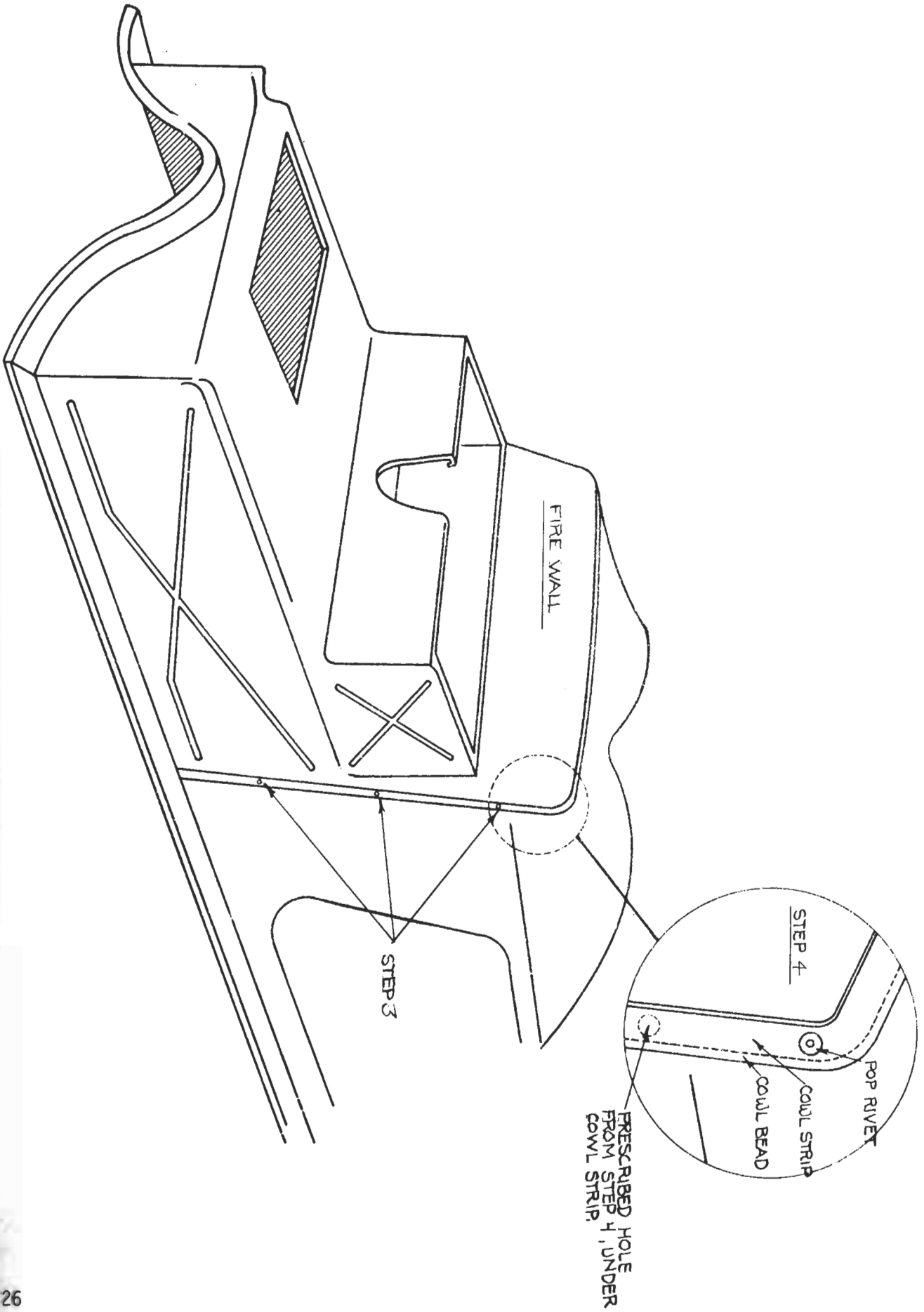

ATTACHING HOOD SIDES - FIG. 4.3

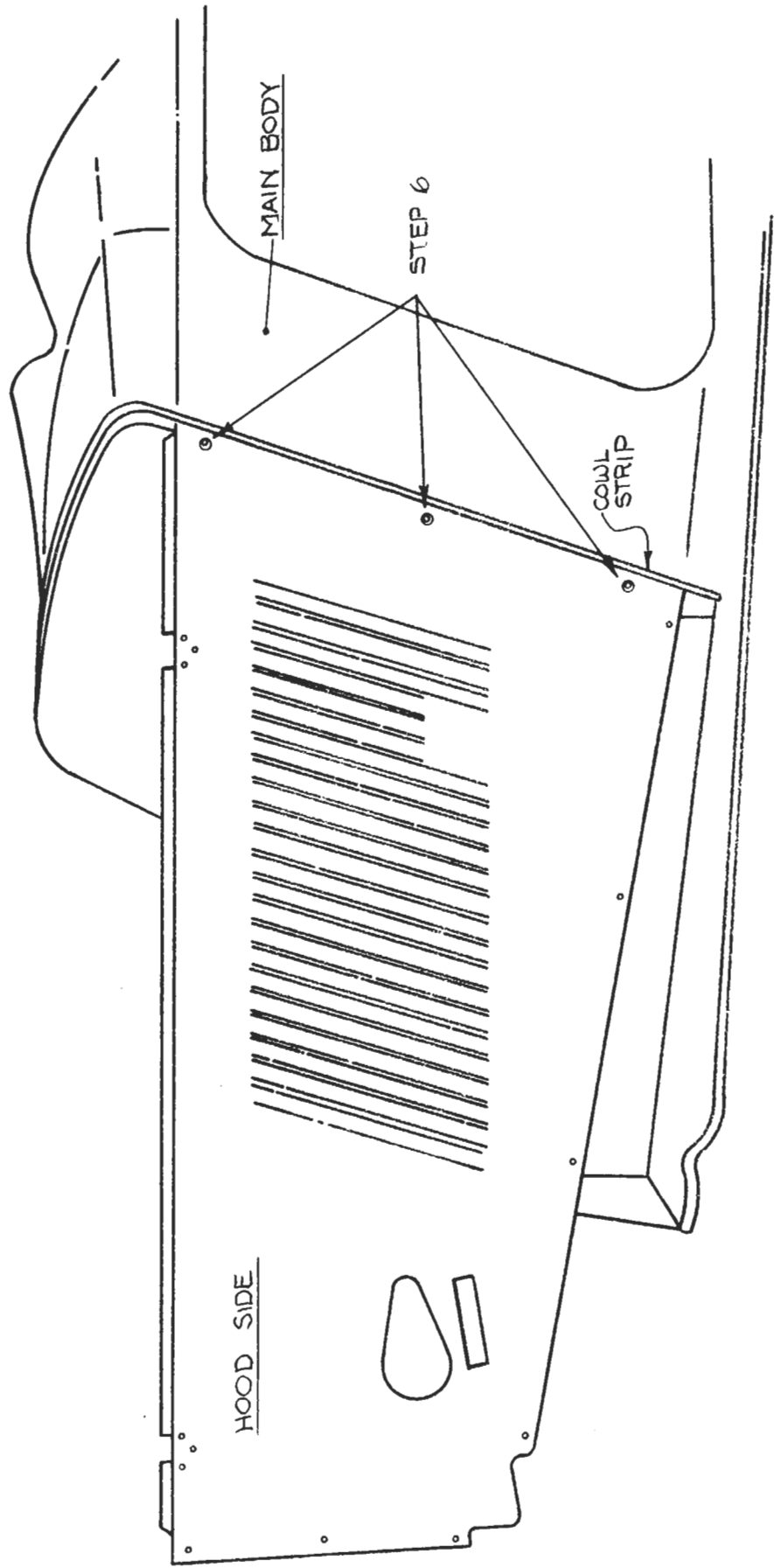

5. FRONT FENDERS

Fiberfab Parts Required:

M500	Front Fenders
M513	Fenderwelt
M555	Bolt Kit
M557	Running board separators

Tools and Materials Required:

Sabre Saw
File
Wrench
Scissors
Electric Drill
Drill Bits: 11/64", 1/4", 5/16"

1. Drill out the six prescribed holes on the inner front fender flange, and two on the front fender flange where the front fender meets the running board. Use a 5/16" drill bit. (Fig. 5.1)
2. Trim along the prescribed lines on the fender flange of the driver side fender, and on the outer curve of both fenders. File the edges smooth. (Fig. 5.1)
3. Drill out the two prescribed bolt holes and one slotted hole at the top of each fender, where the headlight brackets fit. Use a 1/4" drill bit for the bolt holes. Use an 11/64" drill fit for the slotted holes, drilling a series of joined holes to form one long hole (Fig. 5.1)
4. Attach the front fender to the main body and hood side, lining up the prescribed drilled holes in the fender flange with those in the hood sides and main body. Use 1/4 x 1 1/2" bolts. Do not secure the bolts firmly. Tighten the nuts only to the point where they will hold the fender in place. There should be approximately 1/4" between fender and hood side. (Fig. 5.2)
5. Cut a piece of fenderwelt 7' long. Insert the fenderwelt between the running board and main body, and between the front fender and the main body. Allow any excess fenderwelt to extend at the front of the fender. The fenderwelt will buckle at the bolted points. Mark these points on the fenderwelt.
6. Remove the fenderwelt. Cut 1" rounded notches in the fenderwelt, to within 1/4" of the bead, at the points marked in Step 5. (Fig. 5.2)
7. Insert the 4 bolts attaching the running board to the front and rear fenders, using 1/4 x 1 1/2" bolts. Do not secure the bolts firmly.

- 8.) Reinsert the fenderwelt between the fender and the good side, and between the running board and the main body. Secure the nuts and bolts. While tightening each bolt, hold the fenderwelt in place. The bead of the fenderwelt should fit snugly against fender or running board, and the body or hood side. Trim any excess fenderwelt at the bottom front edge of the front fender. (Fig. 5.2)
9. Insert the runningboard separators between the running boards and the front fenders. Cut notches in the separator where it fits over the bolts, to within 1/2" of the bead. Tighten the bolts attaching the running board to the front and rear fenders. Trim the separators to align with the outside lower edges of the running boards and the front fenders. (Fig. 5.2) Note: When securing the runningboards to the rear fenders, place 3, 1/4" washers between the runningboard and rear fender. These washers simulate the original spacers that separated the runningboards and rear fenders on the original MGTD. They are necessary for proper alignment.

MOUNTING FRONT FENDERS FIG. 5.1

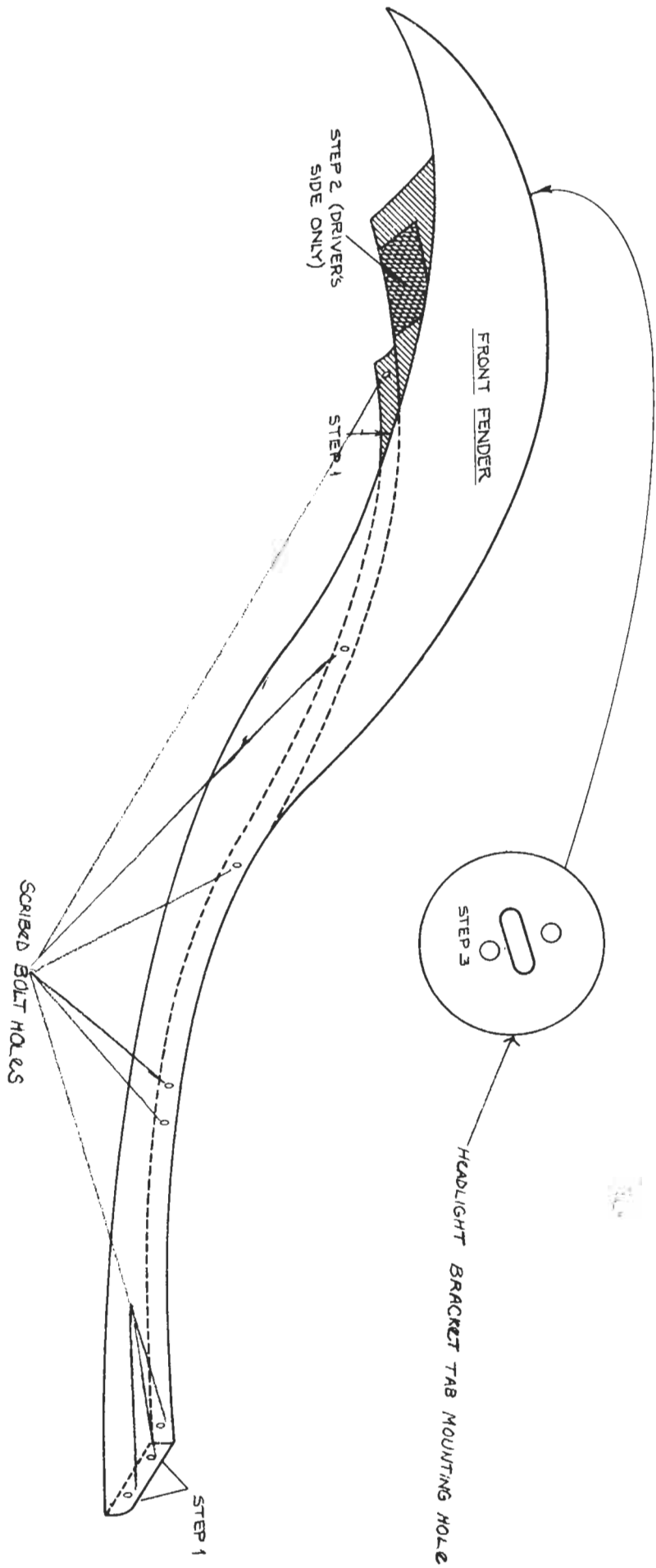

MOUNTING FRONT FENDERS · FIG. 5.2

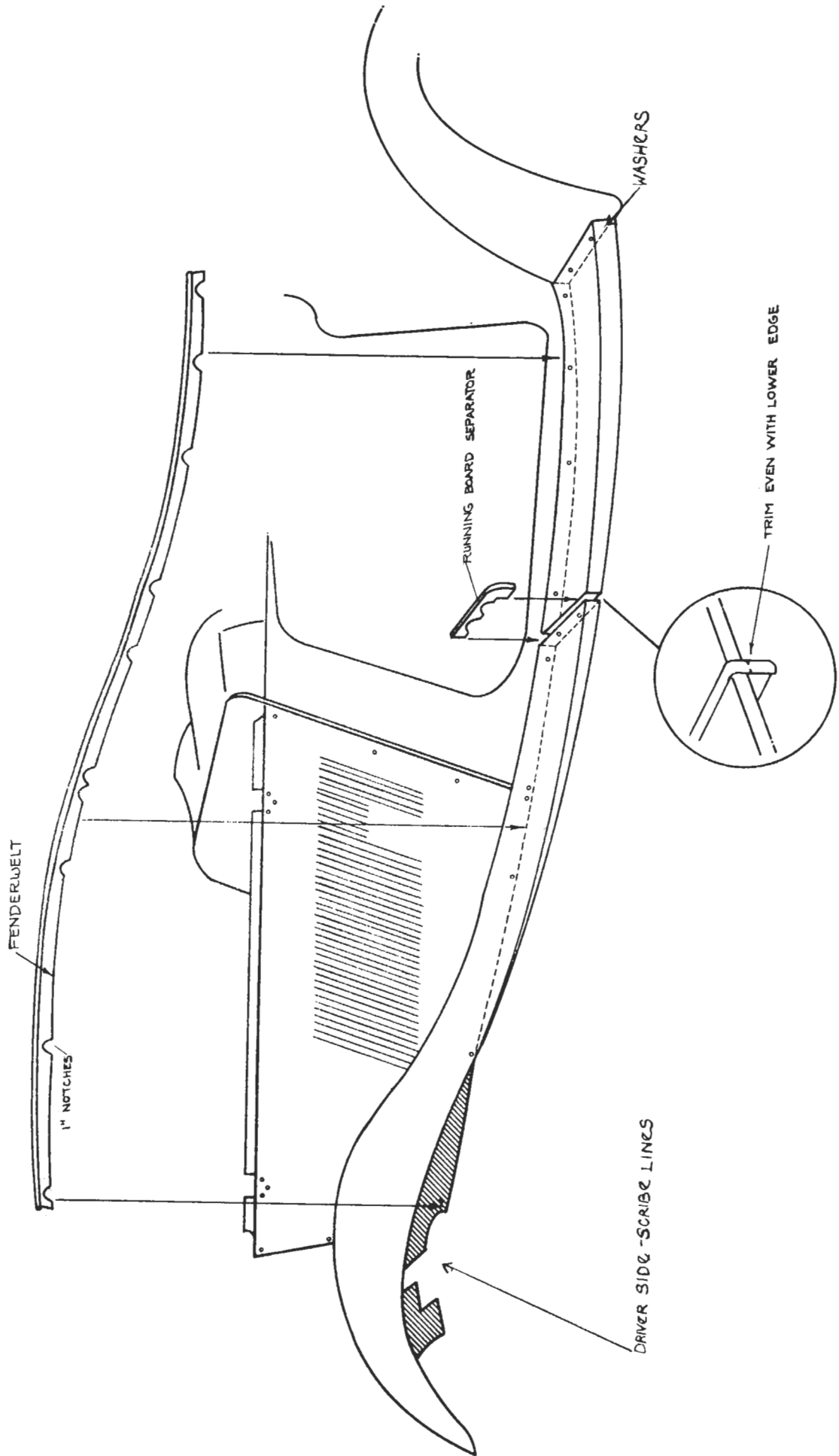

Use Instructions packed grille shell with

6. GRILLE SHELL PREPARATION

Fiberfab Parts Required:

M500	Grille Shell
M513	Fenderwelt
M517	Headlight Brackets
M534	Grille Louvers
M555	Bolt Kit
MX194	Contact Cement

Tools and Materials Required:

Sabre Saw
Scissors
File
Scribe
Wrench
Screwdriver
Electric Drill
Drill Bits: $\frac{1}{4}$ ", 5/16"

1. Cut out the two front inner panels on the grille shell, and file smooth to the scribe line. Trim the outer edges of the grille shell along the prescribed lines, and file smooth. (Caution! Be careful in trimming the grille shell not to nick the edges. File carefully!) See Fig. 6.1
2. Drill out the two prescribed holes on the driver side and four prescribed holes on the passenger side at the front base of the grille shell, where it mounts over the front fenders. Use a 5/16" drill bit. Drill out the two prescribed holes in each side at the front base of the grille shell, using a 5/16" drill bit. Drill out the six prescribed holes on the grille shell side flanges, using a 5/16" drill bit. (Fig. 6.1)
3. Drill out the two prescribed holes and the slotted hole on each side of the grille shell, where the large headlight T-bracket fits, Use a $\frac{1}{4}$ " drill bit. (Fig. 6.1)
4. Position the grille inset on the inside of the grille shell, black side facing front. Scribe holes and notches on each side of the inset, where the large headlight T-bracket fits. The grille shell holes will act as a guide. Remove the inset and drill out the holes, using a $\frac{1}{4}$ " drill bit. (Fig. 6.1)
5. Remove the four nuts and bolts from the top corners and at the center top and bottom of the chrome grille louver frame.
6. Position the grille louvers against the inset, bending the louver frame slightly to fit against the inset. Scribe four holes for attaching the louvers to the inset, and drill using a $\frac{1}{4}$ " drill bit. Attach the grille louvers to the inset, using 10-32 x $1\frac{1}{2}$ " bolts with nuts.

7. Scribe drill holes for attaching the four shortened end louvers (two on each side) to the inset. Drill out the holes, using a $\frac{1}{4}$ " drill bit. Attach the louvers to the inset, using 10-32 x $1\frac{1}{2}$ " FHMS bolts with nuts. (Fig. 6.1)
8. The grille inset and the chromelouvers are attached to the grille shell with the headlight brackets. Note: When using chrome headlight brackets, installation is the same. Position the inset in the grille shell, aligning the drilled holes on each side. Insert the large T-bracket of the headlight bracket assembly from the inside, so that the bolt holes are aligned with the drilled holes in the grille shell and inset, and the bracket tab extends through the slotted hole. The T-brackets will only fit into the grille shell in one position, as one side of the "T" is longer than the other. Bolt the T-bracket into place at the bottom only of each T-bracket, inserting bolts from the outside of the grille shell to the inside. Use $\frac{1}{4}$ -20 x $1\frac{1}{2}$ " HHCS bolts and nuts.
9. Place the long flat bracket of the headlight bracket assembly across the inside of the grille shell, and line up the bolt holes on either end with the top bolt holes in each T-bracket. Bolt together the long bracket, T-bracket, and grille shell with inset and louvers, inserting the bolts from the outside of the grille shell to the inside. Use $\frac{1}{4}$ -20 x $1\frac{1}{2}$ " HHCS bolts and nuts.
10. Cut a piece of fenderwelt 20" long, and position it underneath the driver side only at the base of the grille shell, with the bead lining the edge of the grille shell. Notch corner points in the fenderwelt, and glue it into place with contact cement.

PREPARATION OF GRILL SHELL FIG. 6.1

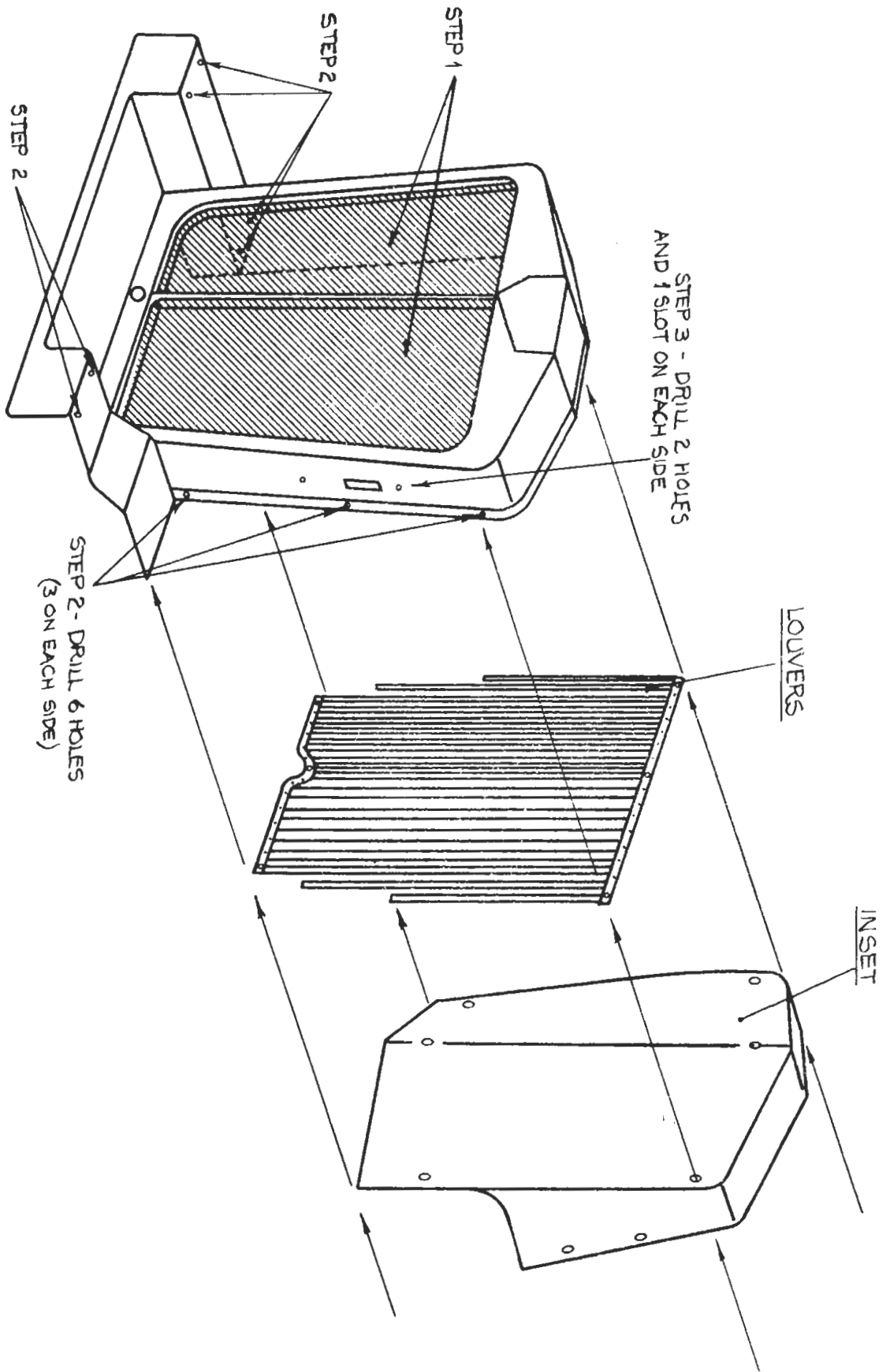

7. GRILLE SHELL ATTACHMENT

Fiberfab Parts Required:

M500 Grille Shell
M513 Fenderwelt
M555 Bolt Kit

Tools and Materials Required:

File
Wrench
Clamps or vice grips
Screwdriver
Scissors
Electric Drill
Drill bits: 1/8"

1. Position the grille shell over the front fenders. Line up the driver side of the grille shell with the trimmed driver hood side, and align the prescribed drilled holes in grille shell flange with those in each hood side. Trim the grille shell by filing where necessary, to insure a tight fit. Bolt the grille shell to each hood side at three points. Use $\frac{1}{4}$ -20 x $1\frac{1}{2}$ " phillips bolts and nuts.
2. Clamp the base of the grille shell to the inner flat panel on the front fenders. Using a $\frac{5}{16}$ " drill bit, drill through the front fenders at six points, using the predrilled holes on the grille shell as a guide. Bolt the grille shell to the front fenders, using $\frac{1}{4}$ -20 X $1\frac{1}{2}$ " phillips bolts and nuts. On the passenger side of the grille shell, the bolts should be secured loosely, allowing approximately $\frac{1}{4}$ " between the grille shell base and the fender. (Fig. 7.1)
3. Cut a piece of fenderwelt 14" long. Insert the fenderwelt between the fender and the grille shell base at the passenger side. Notch the fenderwelt at corner points and at bolt points. Holding the fenderwelt in place, tighten the four bolts attaching the fender to the grille shell. The fenderwelt beneath the grille shell should meet the end of the fenderwelt between the front fender and hood side, and the bead of the fenderwelt should fit snugly against the edge of the grille shell base.

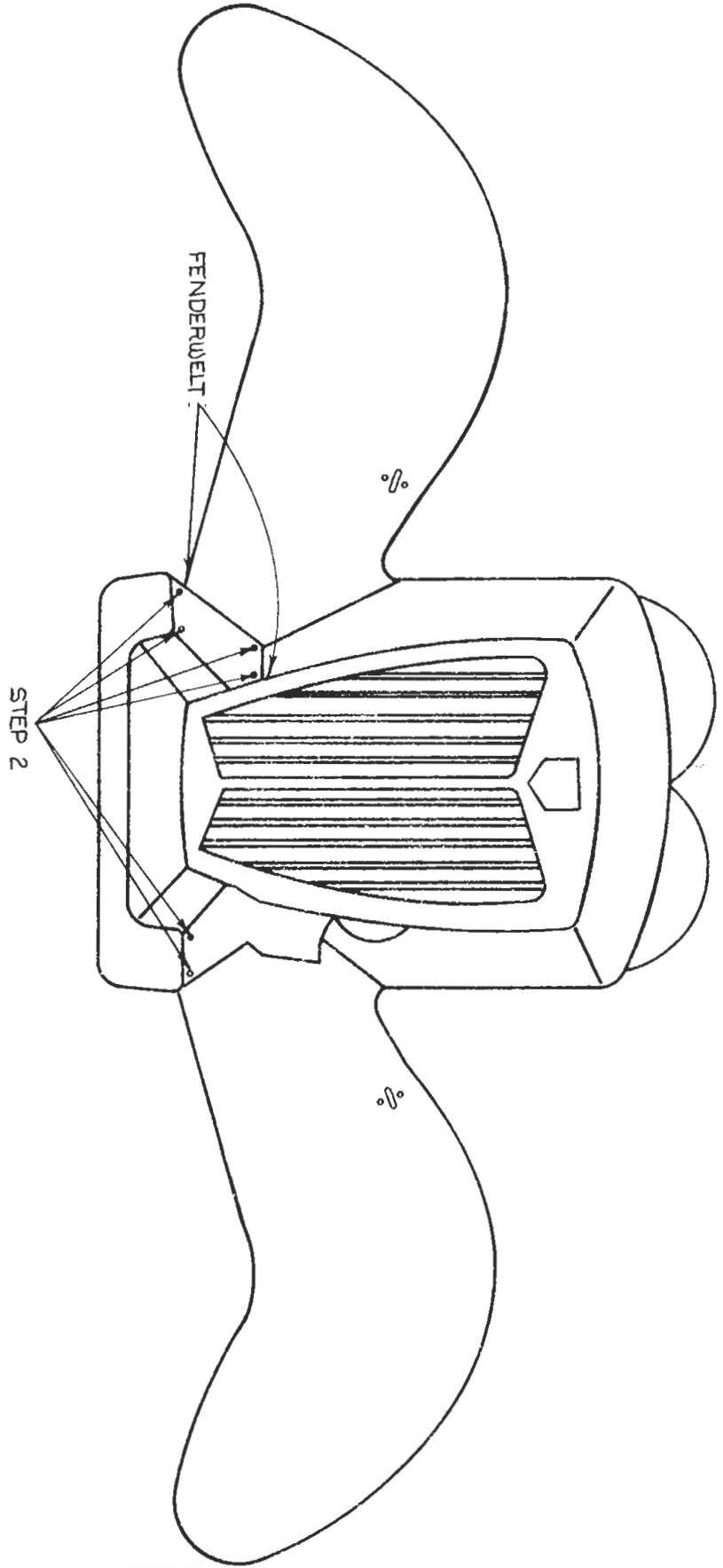

8. HEADLIGHTS AND RUNNING LIGHTS

Fiberfab Parts Required:

M517 Headlight Brackets
M520 Headlights
M526 Running Lights

Tools and Materials Required:

Wrench
Electric Drill
Drill bit: $\frac{1}{4}$ "
Hole Saw: 1"

1. Insert the small T-bracket of the headlight bracket assembly from behind the front fender, so that the bracket tab extends through the slotted hole to the outside of the fender. Bolt the bracket into place, using $\frac{1}{4}$ -20 x $1\frac{1}{2}$ " phillips bolts and nuts. (Fig. 8.1)
2. Attach the horseshoe brackets to the T-bracket tabs extending through the grille shell. The tab at the base of the horseshoe brackets should extend toward the rear of the car, and the wider curved side of the bracket attaches to the fender T-brackets. Use $\frac{1}{4}$ -20 x $1\frac{1}{2}$ " phillips bolts and nuts. (Fig. 8.1)
3. Drill a small hole directly behind each headlight bracket on the grille shell, using a $\frac{1}{4}$ " bit. These drill holes will allow for wiring connections at a later step.
4. Place the rim supplied with the headlight over the headlight bolt, and insert the headlight bolt through the tab on the horseshoe bracket, as shown in Fig. 8.1. Secure the headlight with nuts and washers supplied with the headlights.
5. Position the rubber gasket of the running lights upside down on the front fender. The front edge of the gasket should be 15" from the uppermost front edge of the fender, and the side of the gasket should be 5" from the highest side edge of the fender. Scribe the front and rear bolt holes from the gasket onto the fender, as shown in Fig. 8.1.
6. Drill out the front and rear bolt holes scribed above, using a $1/8$ " drill bit. Centered between the two bolt holes, use a 1" hole saw to drill a hole for the lower portion of the gasket.
7. Place the gasket onto the fender, with the lower portion of the gasket extending to the underneath to allow for the wiring. Place the light assembly consisting of bulb, socket, and covering lens, onto the gasket. The screws supplied with the lights should be inserted through the socket

plate and gasket, to attach to the fender.

- 8\ Bolt the light assembly into place from underneath the fender, using the nuts and washers supplied with the lights.

MOUNTING HEADLIGHTS & FRONT RUNNING LIGHTS FIG. 8.

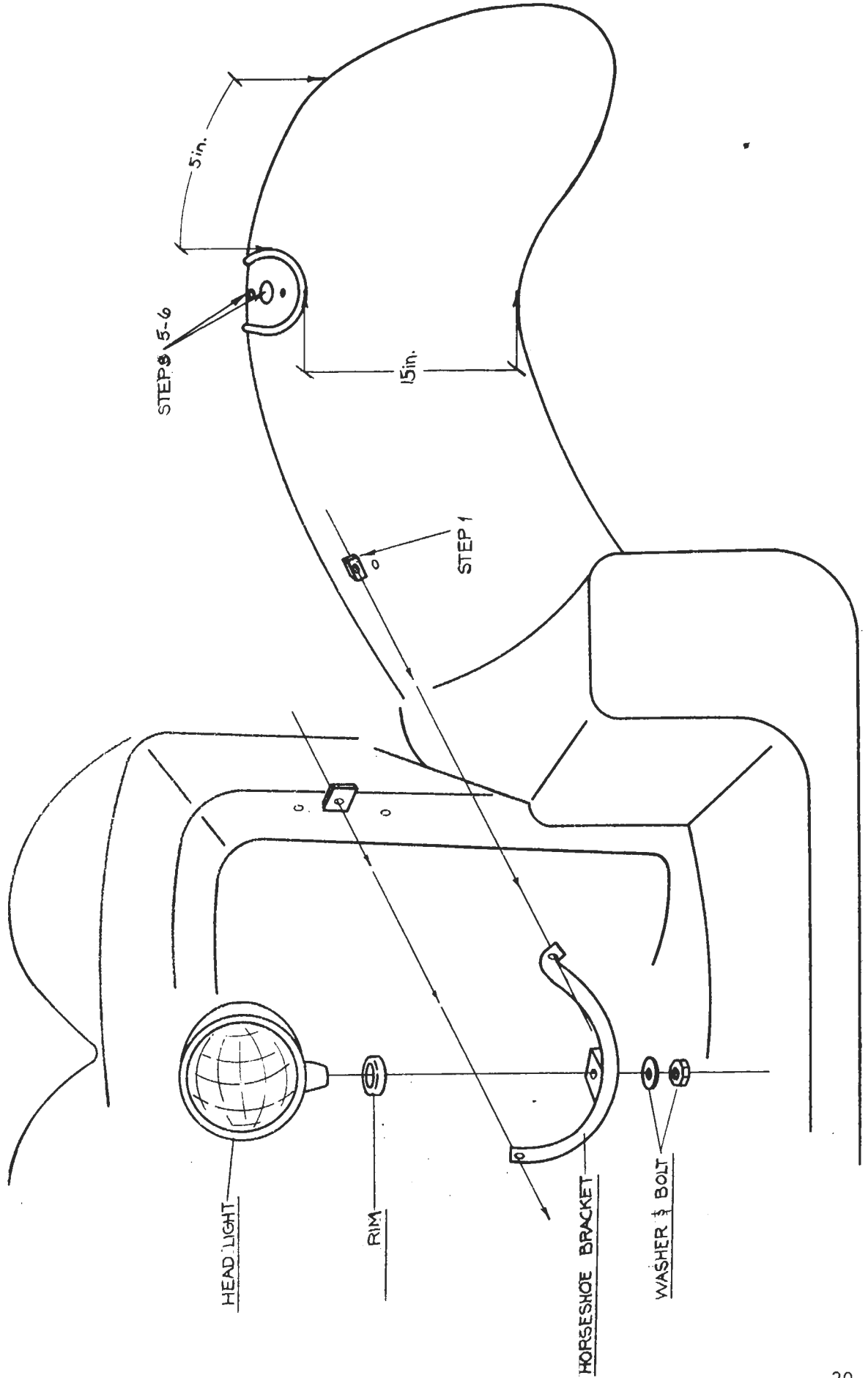

9. DOOR HANDLES AND LATCHES

Fiberfab Parts Required:

M500	Doors
M514	Door Latches
M515	Door handles
M527	Door Panels (from Upholstery Kit)
M555	Bolt Kit

Tools and Materials Required:

Scribe
Hack Saw
Screwdriver
Wrench
Electric Drill
Drill bits: 1/8", 5/16", 11/32", 1/2"

1. Position the interior door panels on the inside of each door. Using the panel as a template, scribe the cut-out area for the inside latch onto the inside of the door. (Fig. 9.1)
2. Position the inside latch in the area scribed in Step 1. The latch handle should move downward. Scribe holes for the four corner screws and drill, using an 11/32" drill bit.
3. Attach the latch to the inside of the door, at the four corners. Use 1/4-20 x 1 1/2" philips bolts and nuts.
4. Drill through the square cut hole in the center of the latch, using a 5/16" drill bit. Drill through both the inside and the outside of the door. The latch hole will act as a guide for the drill bit. The resulting drill hole on the outside of the door will locate the position for the outside door handle. (Fig. 9.2)
5. Re-drill the hole made in Step 4, using a 1/2" drill bit. Drill from the outside of the door to the inside, until the drill bit hits the metal door latch. (Fig. 9.2)
6. Insert the outside door handle through the hole made in Step 5. (Note: It is helpful to push the handle shaft through the square cut hole in the door patch first, to "open" the drill hole.) Scribe a line where any excess handle shaft extends past the door latch on the inside of the door. (Fig. 9.2)
7. Remove the outside door handle, and cut the excess shaft along the scribe line made in Step 6. (Fig. 9.2)

8. Reinsert the outside door handle. Drill two holes for the handle screws on the outside of the door, using a 1/8" drill bit. The handle will act as a guide for the drill bit. Screw the handle into place, using 1/4-20 x 1 1/2" phillips bolts and nuts.

DOOR HANDLES & LATCHES FIG. 9/

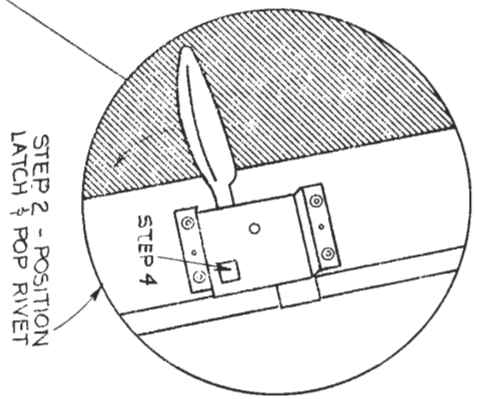
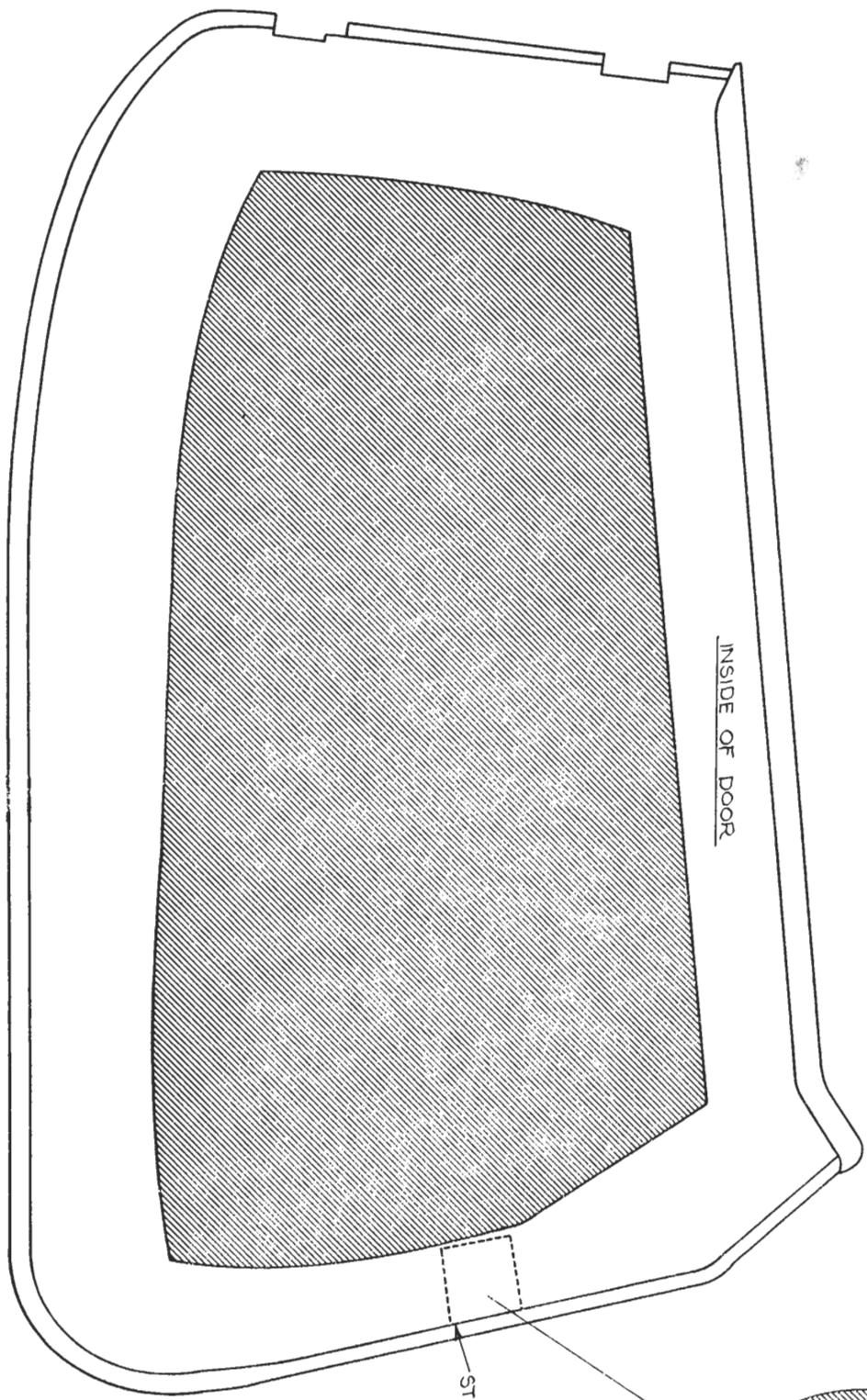

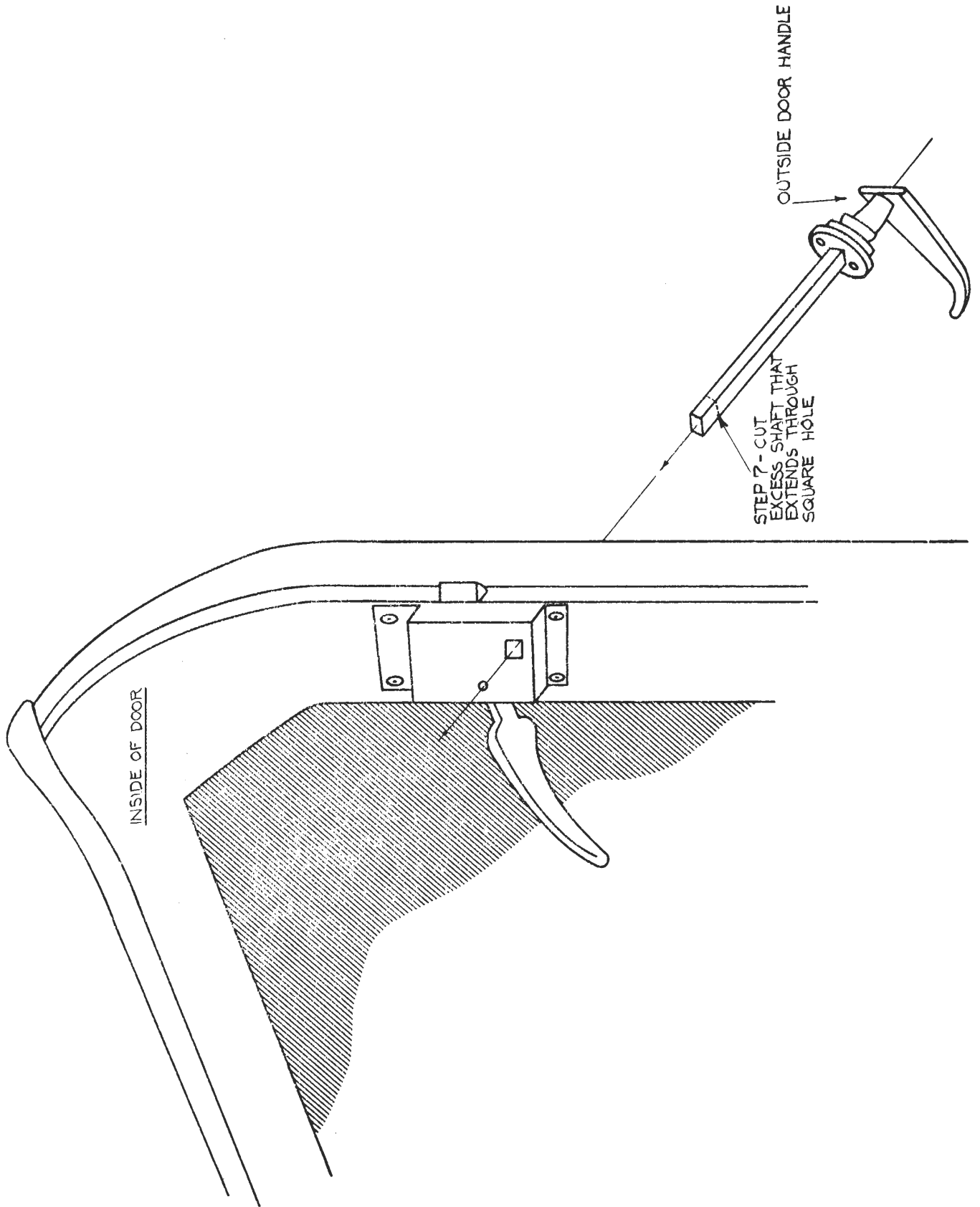

10. MOUNTING DOORS

Fiberfab Parts Required:

M500	Doors
M510	Door Hinges
M527	Door Panels (from Upholstery Kit)
M555	Bolt Kit

Tools and Materials Required:

File
Scribe
Wrench
Screwdriver
Tape
Electric Drill
Drill bits: 1/8", 1/4"

1. File smooth the notched area at the rear of the door, where the door hinges are attached. (Fig. 10.1)
2. Position the two opened door hinges in the notched areas. Hinge pins should point up, and the edge of each hinge should be approximately 1/4" from the edge of the inside door notch. Scribe two bolt holes for each hinge onto the door notch. (Fig. 10.1)
3. Drill out the four holes scribed in Step 2, using a 1/4" drill bit. Attach the hinges to the door, using 1/4"-20 x 1 1/2" AHCS. The hinge pins should be in a straight line, so that door will hang properly on the main body.
4. Position the interior door panels on the inside of the door, and tape it into place. Using a 1/8" drill bit, drill through both the door panel and the inside of the door, at twelve points as shown in Fig. 10.2. Attach the door panel to the inside of the door, using #8 x 1 OH phillips screws.
5. With hinges closed, position the door against the main body. Place a 1/8" to 1/4" spacer (e.g., two thick pieces of cardboard) on the door jam on the main body, where the door rests. Place the door on the spacer and position the door against the main body. Scribe lines around the outer edge of the door hinges, where they meet the main body, at the top and bottom of each hinges. Scribes should be made from the inside of the car. (Fig. 10.3)
6. Open the door. Hold the door in place so that the hinges are aligned with the scribe lines made in Step 5. Scribe the two bolt holes of each hinge onto the main body. Drill, using a 1/4" drill bit. (Fig. 10.3)

7. Attach the door to the main body, using $\frac{1}{4}$ -20 x $1\frac{1}{2}$ " AHCS. Bolt the top hinge to the main body first, and check the alignment of the door. If the alignment is not correct, redrill the bolt holes for the bottom hinge, according to a corrected alignment. Bolt the bottom hinge to the main body. (Fig. 10.3)
8. Do not attach the striker plates at this time. The striker plates will be bolted in place after the main body has been mounted on the chassis, to insure a correct alignment.

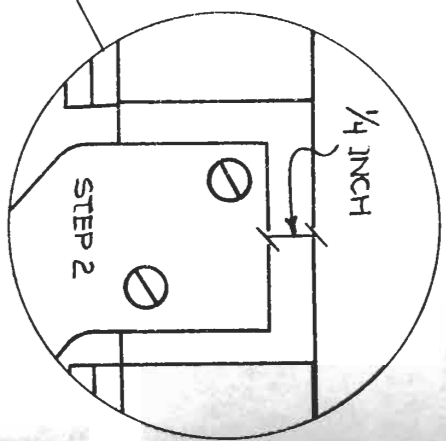
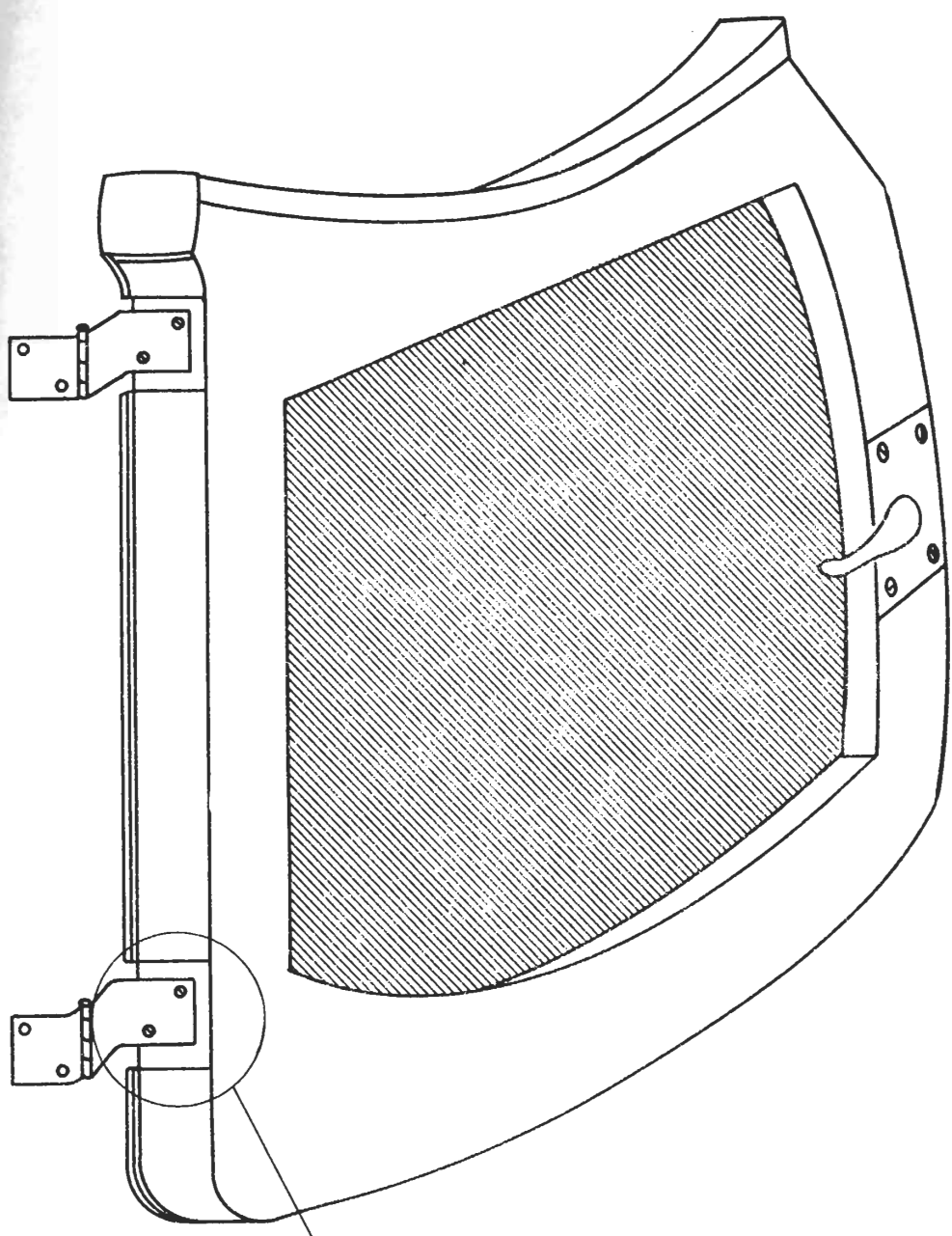

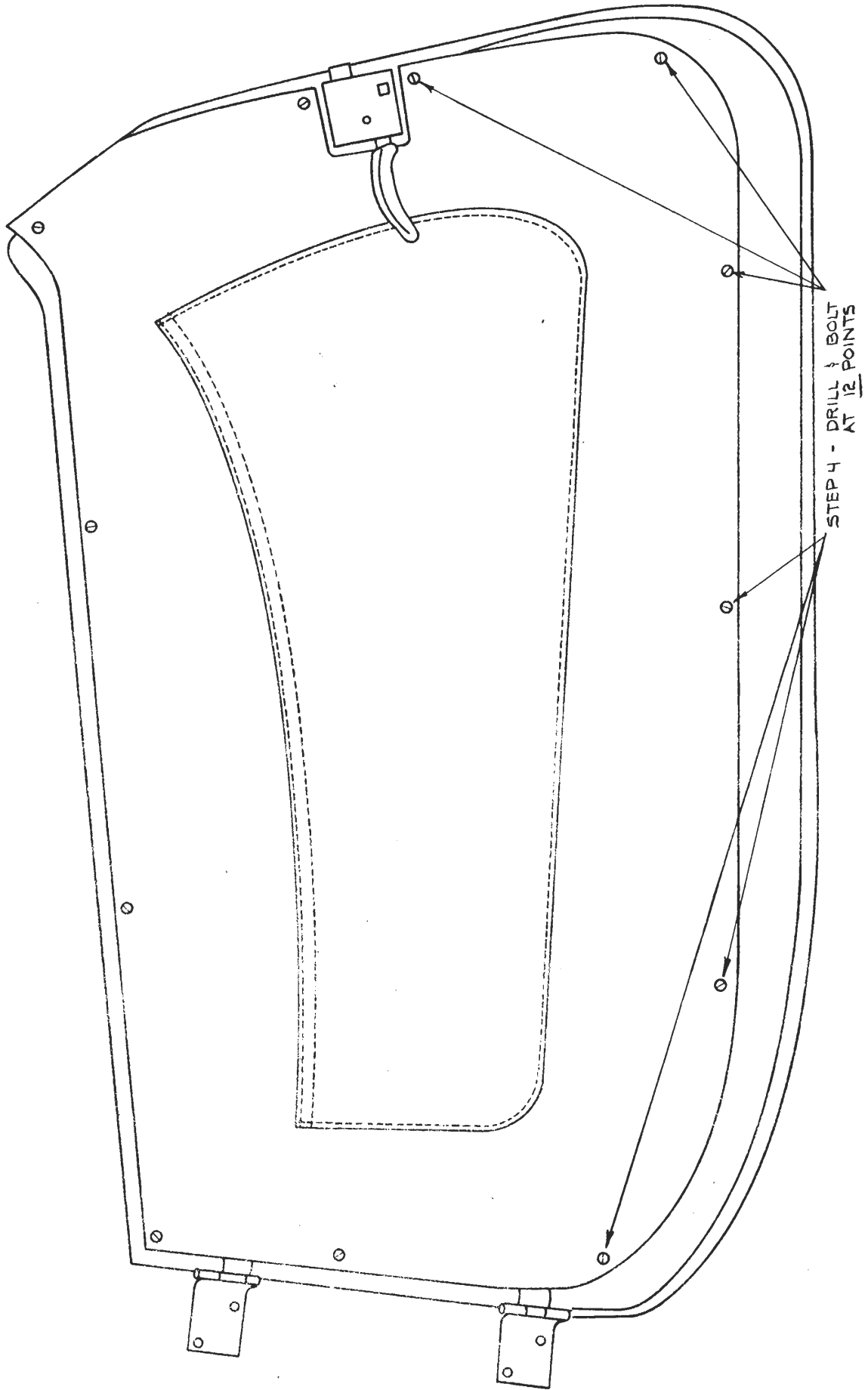

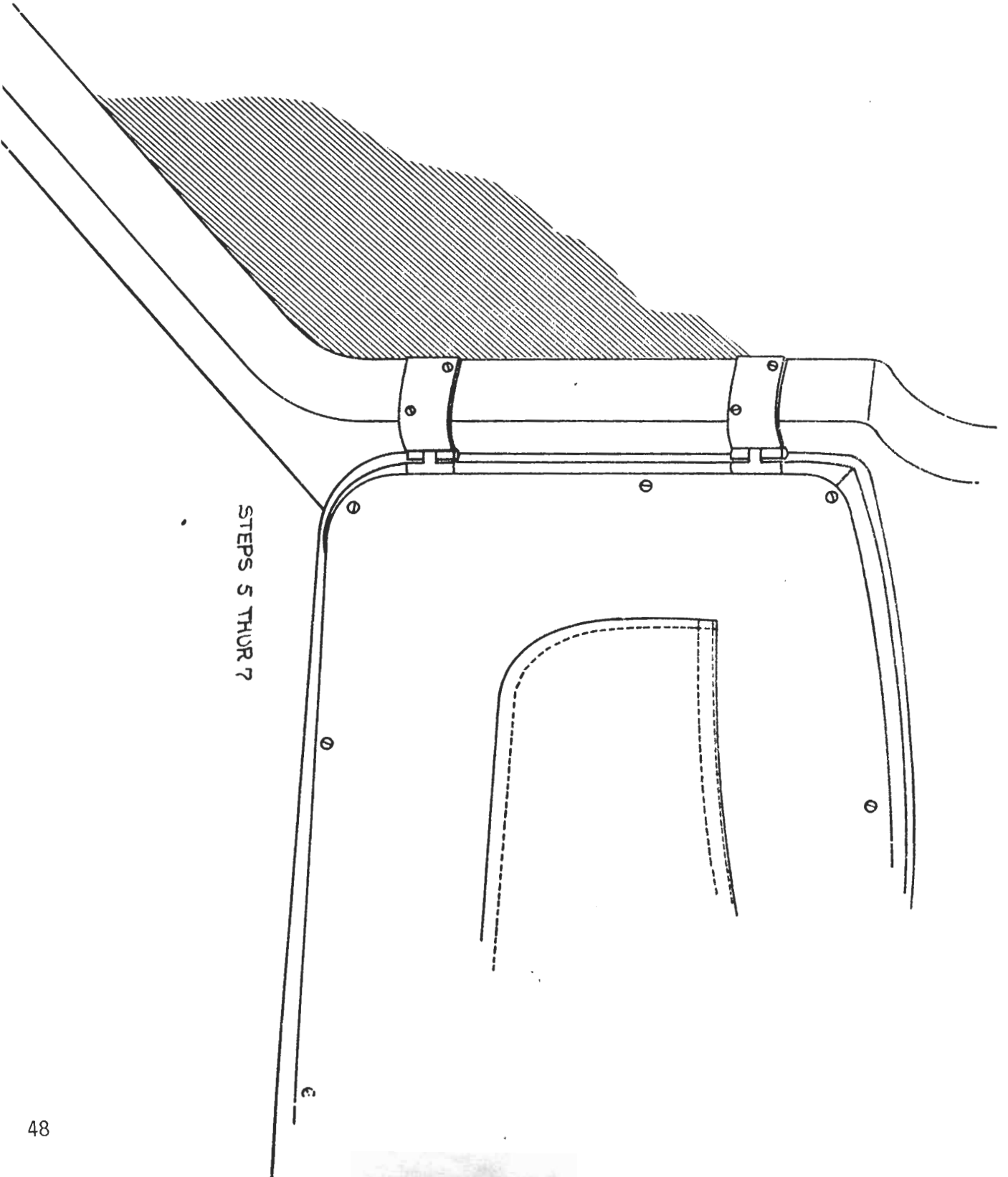

11. INSTALLING TAILLIGHTS

Fiberfab Parts Required:

X173	Single Contact Sockets and Bulbs
X174	Double Contact Sockets and Bulbs
M528	Taillights

Tools and Materials Required:

Soldering Gun
Solder
Scribe
Car Battery
Electric Drill
Drill Bits: 11/64",
Hole Saw: 1"

1. The contact sockets and bulbs supplied with the kit must have a ground wire attached to them for use in the fiberglass car. Insert ground wire up through the bottom of the gasket around the socket. Push the top of the gasket down to reveal the metal portion of the socket. Solder the ground wire to the side of the socket, and replace the gasket around the socket. Each contact socket must have a ground wire.
2. Double contact sockets have two wires extending from the socket; single contact sockets have one wire. The double-filament bulbs should be screwed into the double contact sockets, and the single-filament bulbs are screwed into the single contact sockets.
3. On double contact sockets, the two wires may not be differentiated by color. Touch the soldered ground wire to the negative post of a 12 Volt battery. Touch one wire at a time to the positive post. The brighter light indicates the turn signal wire. Mark this wire by knotting it, to facilitate wiring connections at a later step.
4. Position the taillight lens and metal rim on the raised flat surface of the rear fender. Scribe the two mounting holes onto the rear fender, by inserting the scribe or a thin nail through the holes on each side of the lens. Remove the lens and drill out the scribed holes, using an 11/64" drill bit.
5. Drill out two holes to allow for the insertion of the contact sockets and bulbs, using a 1" hole saw. Fig. 11.1 shows the position of the holes on the rear fenders.

6. Insert the single and double contact sockets and bulbs into the 1" holes, the single contact socket in the top hole and the double contact socket in the lower hole. Insert the sockets from behind the fender, until the metal clamp ring extends through the hole to the front of the fender.
7. Bolt the lens with rim into place over the bulbs. The metal insert inside the lens should be placed between the two contact sockets, and the mounting holes should align with those drilled in the fender. Secure the lens in place, using 8-32 x 2" machine screws.

INSTALLING TAIL LIGHTS FIG. 11.1

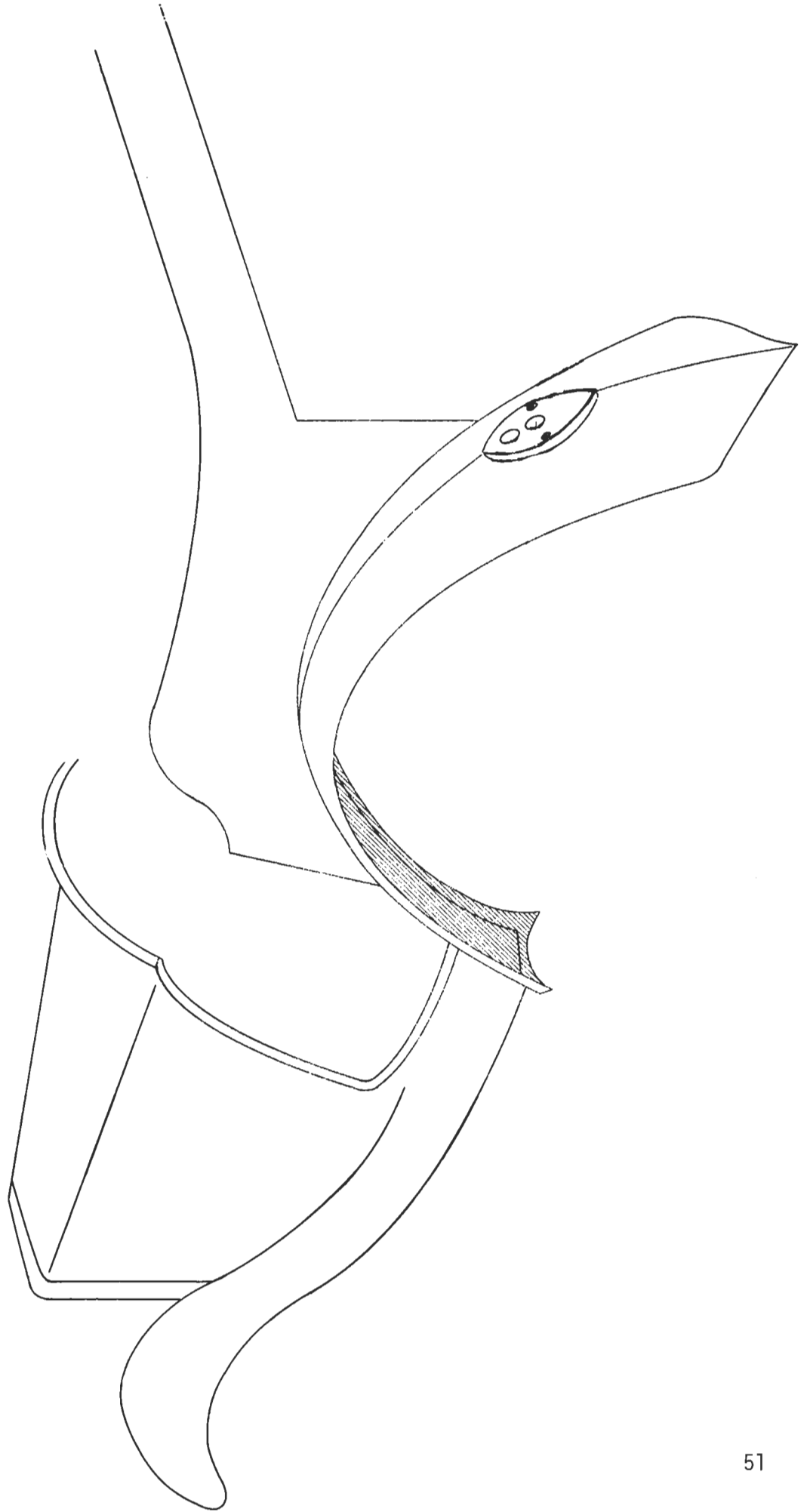

12 UNDERDASH ASSEMBLY

Fiberfab Parts Required:

Defroster Kit
Dimmer Switch
Wiper Motor
Fuse Block

Tools and Materials Required:

1. Position the defroster motor as illustrated in Fig. 12.1, with the motor extending inside the car. Scribe through the motor mounting holes to locate drill holes on the firewall. Drill these holes, using an 11/64" drill bit.
2. Mount the defroster motor on the firewall bulkhead, using 1/4 x 2 1/2" stove bolts and 1/4" washers. Skim the motor away from the firewall bulkhead by placing three washers on each side between the motor and the firewall. This will allow the defroster to draw interior air.
3. At the top front of the main body, locate the prescribed hole centered over the dash board area. Drill, using a 3" hole saw. (Fig. 12.2)
4. Insert the defogger vent through the 3" hole. Place the metal brackets included in the defroster kit over the bottom of the vent from underneath the dash board area. Secure the bracket with wingnuts included in the defogger kit. (Fig. 12.3)
5. Insert the fuses in the fuse block supplied with the wiring harness. Bolt the fuse block to the firewall at the upper corner passenger side, as shown in Fig. 12.1)
6. Drill a 1" hole through the firewall at the driver's side, approximately 2" below the gas tank bib hole, as shown in Fig. 12.1. Use a 1" hole saw.
7. Insert the dimmer switch through the 1" hole, from the front of the car to the interior. The connections for wiring should remain to the front of the firewall.

UNDER DASH ASSEMBLY FIG. 12.1

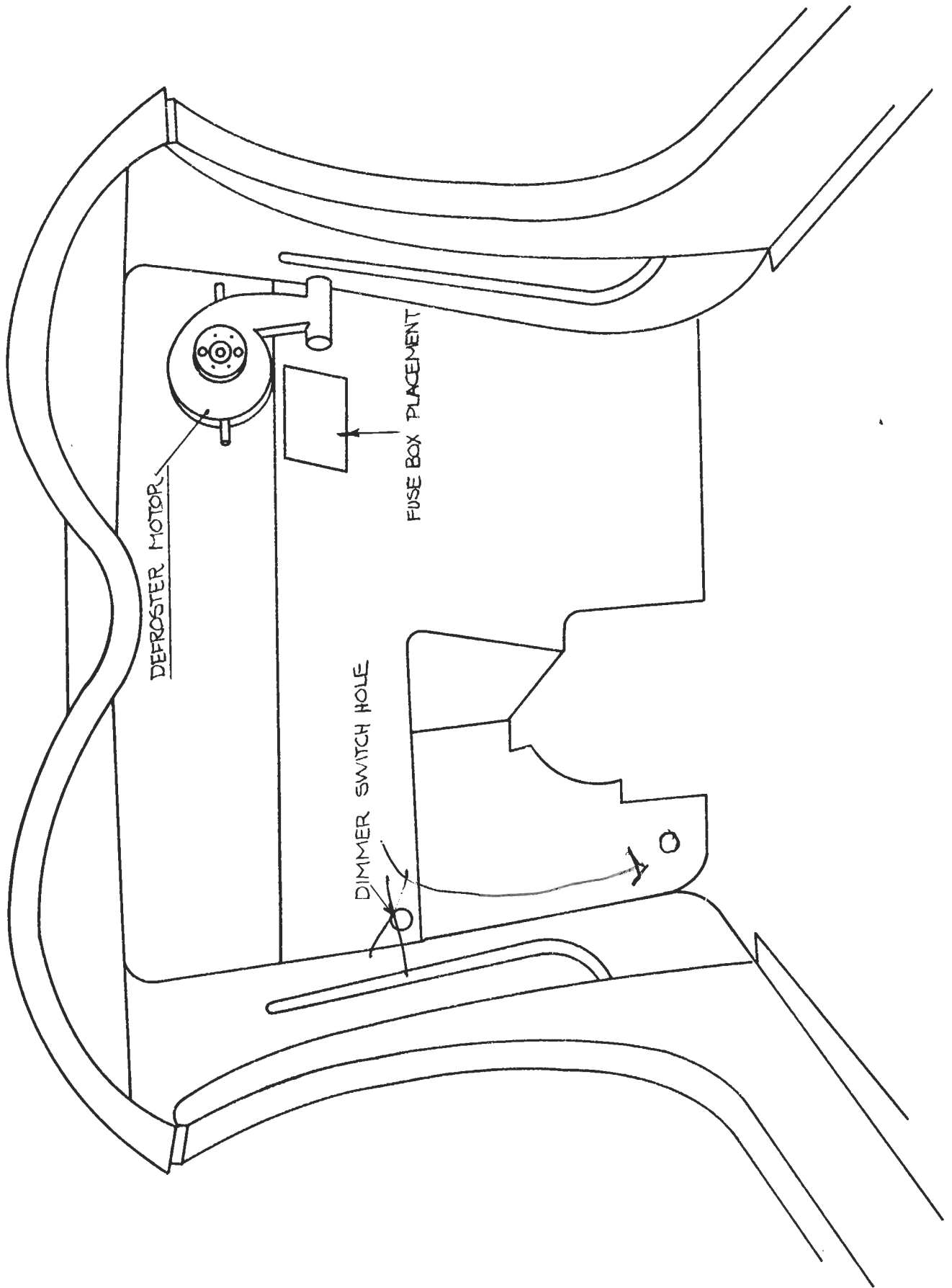

DEFOGGER - DEFROSTER VENT FIG. 12.2

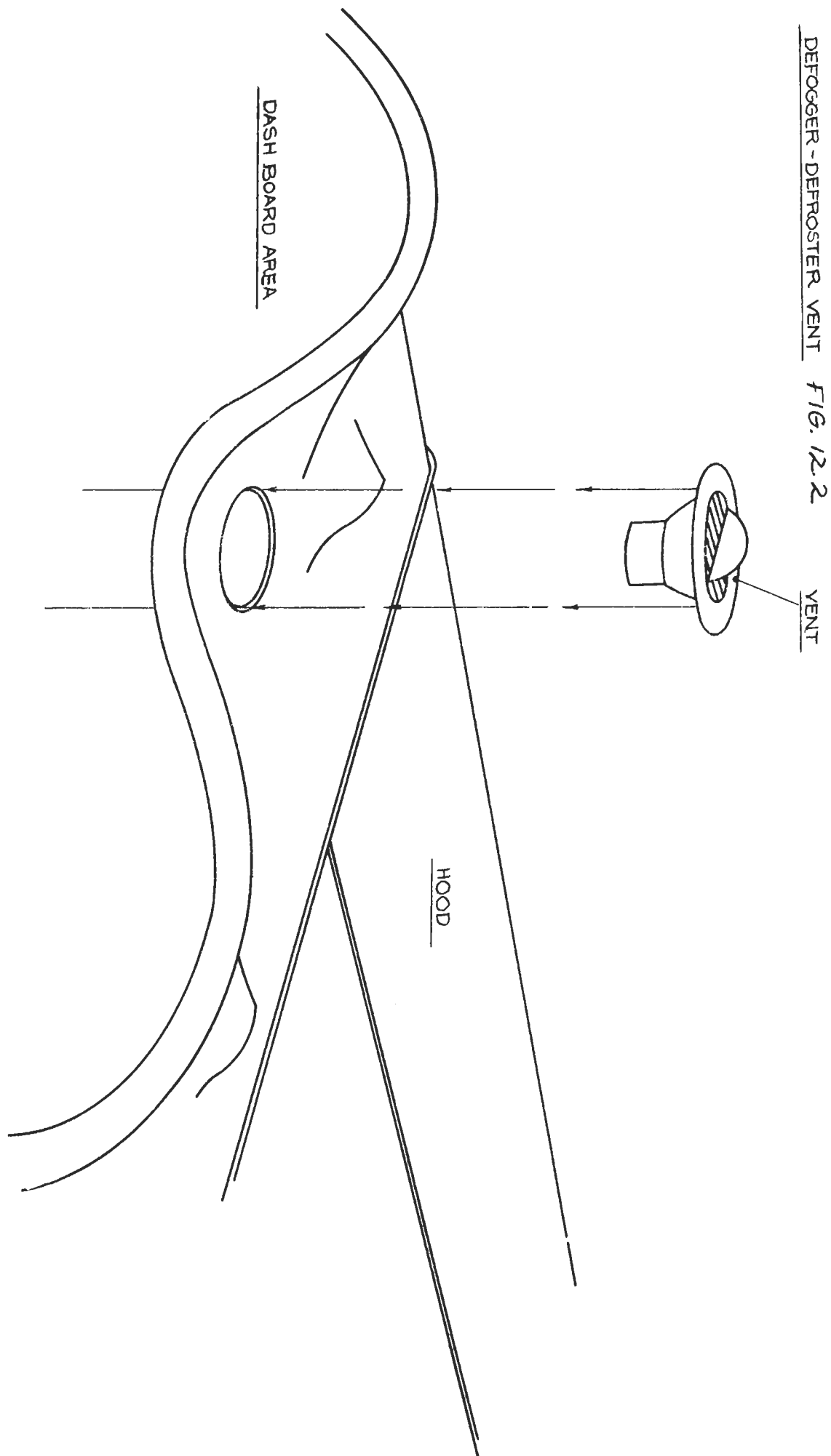

DEFROSTER - DEFOGGER VENT FIG. 12.3

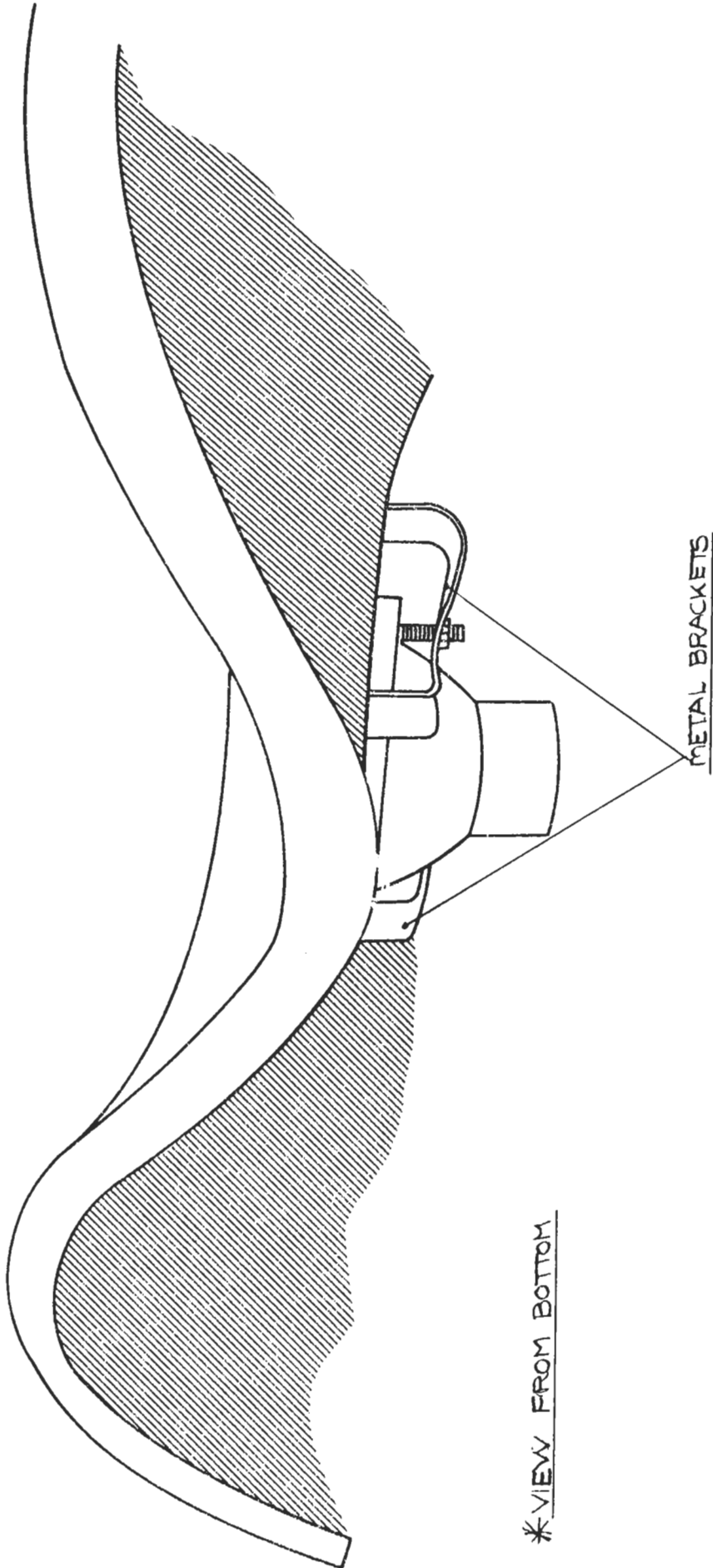

*VIEW FROM BOTTOM

13. WINDSHIELD WIPER ASSEMBLY

Fiberfab Parts Required:

M521 Wiper Arms and Blades

Tools and Materials Required:

Wiper Motor - from disassembled VW
Electric Drill
Drill bit: 3/8"

1. Position the wiper motor on the outside of the car, with wiper knobs against the two raised areas in the front of the windshield area, to locate the position for drilling. Scribe the main body at these points by pushing the knobs against the body at these points (Fig. 13.1)
2. Drill through the main body at the two points scribed in Step 1, using a 3/8" drill bit.
3. Position the motor against the inside of the firewall, with the wiper knobs extending through the drilled holes. Secure the motor with the nuts from the Volkswagen wiper assembly.
4. Insert two allen screws into the red adaptor included with the wiper arms. Place the adaptor on the wiper knob, and pound into place. Tighten the allen screws.
5. The wiper arms snap into place directly over the adaptors. The wiper blades slide onto the arms and clip into place.

WASHER SYSTEM

Follow the instructions included with the washer kit. Wiring connections can be made when the wiring for the dash board is done.

WINDSHIELD WIPER & MOTOR ASSEMBLY FIG. 13.1

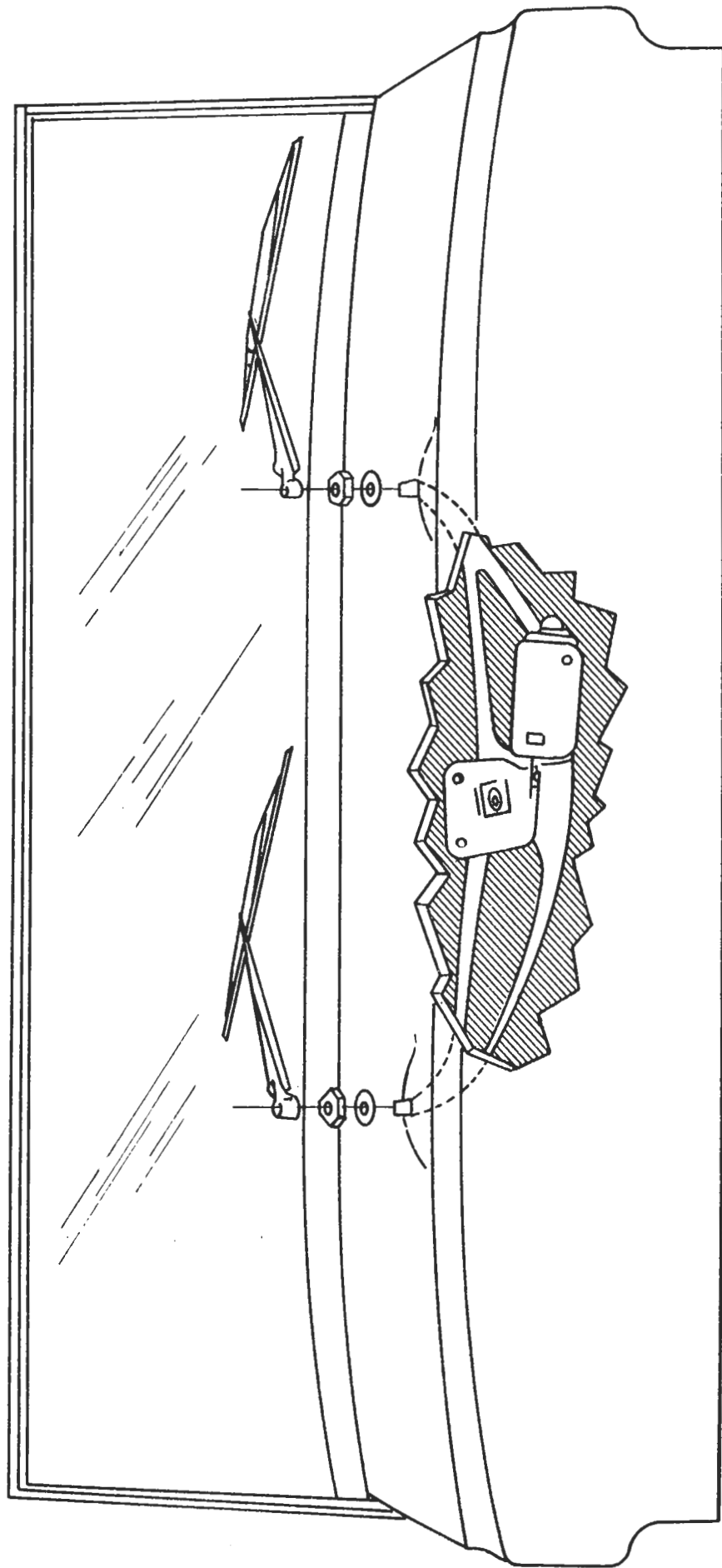

14. DASH BOARD PREPARATION

Fiberfab Parts Required:

X131 Dimmer Switch
X133 Toggle Switches
X134 Red Indicator Light
X135 Green Indicator Light
X136 Headlight Switch
X161 Speedometer
X162 Tachometer
X163 Ammeter
X164 Fuel Gauge
X165 Oil Temperature Gauge
M546 Grab Handle

Tools and Materials Required:

File
Electric Drill
Drill Bits: 5/16" - 1/2" - 1/8"
Hole Saws: 2" - 3"
Screwdriver

1. The tab extending at each corner at the base of the dash board, where the dash bolts to the main body, may have a slightly raised edge underneath. File this edge smooth, so that the dash will fit firmly against the main body at these points.
2. Position the dash board against the main body. Drill through the extending tab and main body, using a 5/16" drill bit. Bolt the dash board into place on each side, using 10-32 x 1/4" bolts and nuts.
3. Locate the two parallel prescribed holes on the driver side of the dash board. Use a 3" hole saw to drill holes locating the position for the speedometer and tachometer (Fig. 14.1).
4. Centered above the speedometer and tachometer holes, locate prescribed hole and drill, using a 1/2" drill bit. The resulting drill hole locates the position for the high beam light (Fig. 14.1).
5. Along the bottom of the center inset on the dash board, drill out five prescribed holes, using a 1/2" drill bit. Drill two prescribed holes at the top corners of the center inset, using a 1/2" drill bit. These holes locate the positions for the ignition switch, toggle switches, oil and pressure indicator lights and headlight switch (Fig. 14.1).
6. Drill three center prescribed holes in the center inset, using a 2" hole saw. The resulting holes locate the positions for the ammeter, fuel gauge and oil temperature gauge (Fig. 14.1).
7. At the passenger side of the dash board, position the grab handle so that the end bolt holes from a line with the two prescribed holes in the dash board, as shown in Fig. 14.1. Drill the bolt holes, using a

1/8" drill bit. Bolt the grab handle to the dash board (Fig. 14.1).

- ✓ 8. Remove the dash board from the main body. Insert the gauges, switches, and lights as show in Fig. 14.1.
- ✓ 9. Bolt the dash board to the main body. To facilitate wiring, the dash board should be bolted upside down, inside facing out. to the main body (Fig. 14.1).

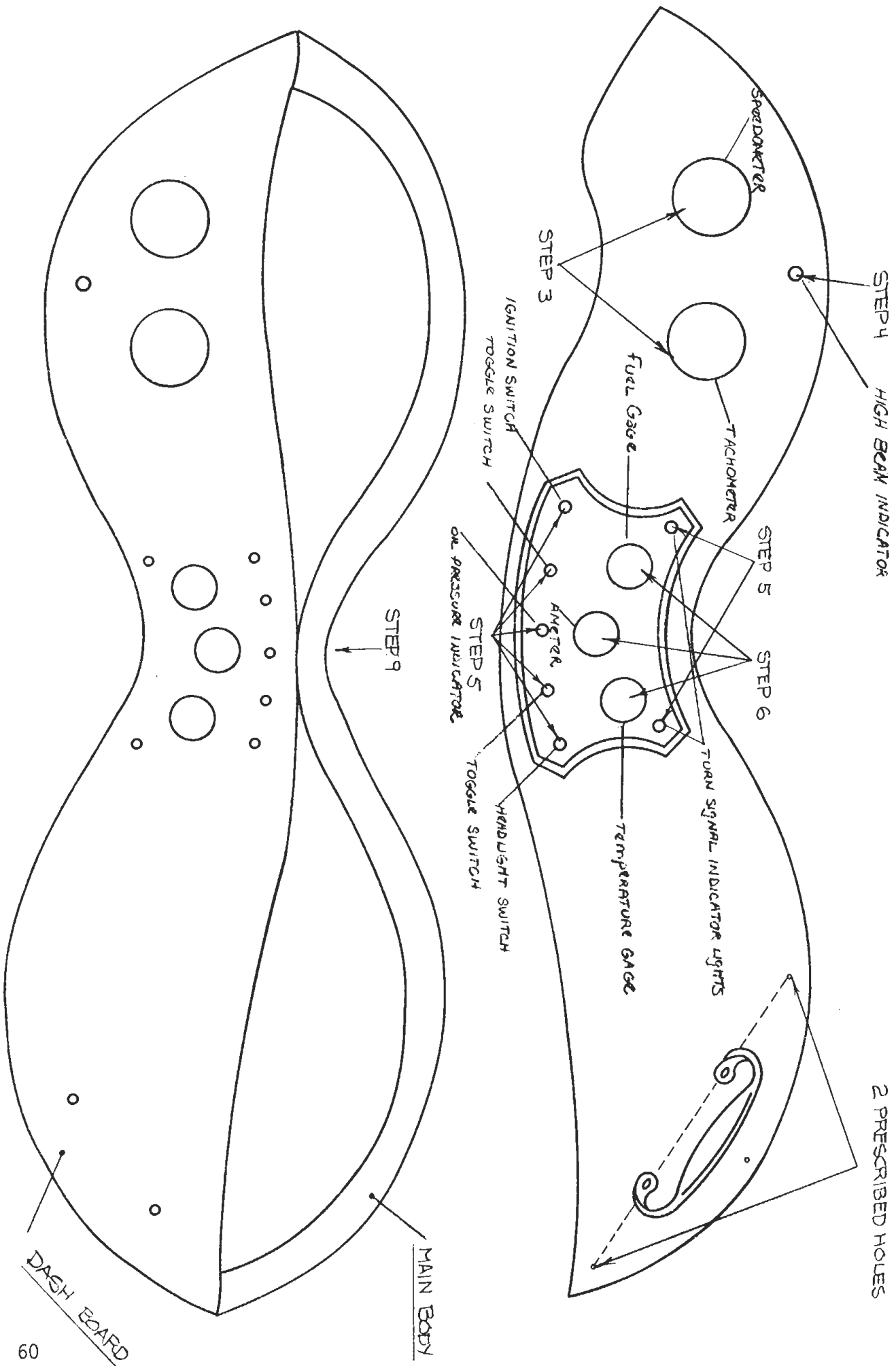

15. PRELIMINARY WIRING INSTALLATION

Fiberfab Parts Required:

M560 Wiring Kit

Tools and Materials Required:

Wire Cutters
Wire Crimpers
Wiring Connections
Electric Drill
Drill Bit: 1/4"
Pop Rivet Gun

1. Position the wiring harness inside the body of the car, so that the main bulk of the harness lies beneath the front interior section of the main body. Wires extending to the rear of the car will pass inside the main body section beneath the door at the passenger side. Wires extending to the front of the car will extend through the holes drilled in the main body section at the passenger side. Consult the wiring diagrams, Fig. 15.1 for wiring connections.
2. Wiring connections should be done in the following order:
~~dash board instrumentation and lighting; under-dash connections,~~
including fuse block, defogger, windshield wiper motor; front firewall connections, including horn, windshield washer, dimmer switch; headlights and running lights; taillights.
3. As each stage of wiring is completed, wires may be pop riveted to the interior of the car using plastic brackets supplied with the wiring harness. The brackets should be secured to the body in places where they will not be seen such as the firewall, fender flanges, inside main body sections, etc.
4. Remaining wiring connections will be completed after the body has been mounted onto the chassis.

16 INSTALLING THE DASH BOARD

Fiberfab Parts Required:

M513 Fenderwelting
M555 Bolt Kit

Tools and Materials Required

Electric Drill
Drill Bit: 1/8"
Scissors
Wrench

1. Bolt the dash board to the main body at the two end tabs, using the bolts from the preliminary attachment. Note: Be very cautious when mounting the dash board, as any pulling or rough handling can sever the wiring connections.
2. Drill out the eight prescribed holes along the rounded edge of the dashboard, using a 1/8" drill bit. Drill through both the dash board and the main body flange. (Fig. 16.1)
3. Cut a piece of fenderwelt 52" to line the upper edge of the dash board. Notch the fenderwelt to allow for the passage of bolts, and to ease the fenderwelt along the rounded edges.
4. Secure the dash board and fenderwelt to the main body, using 10-32 x 1½" bolts and finishing washers.

DASH BOARD FIG. 16.1

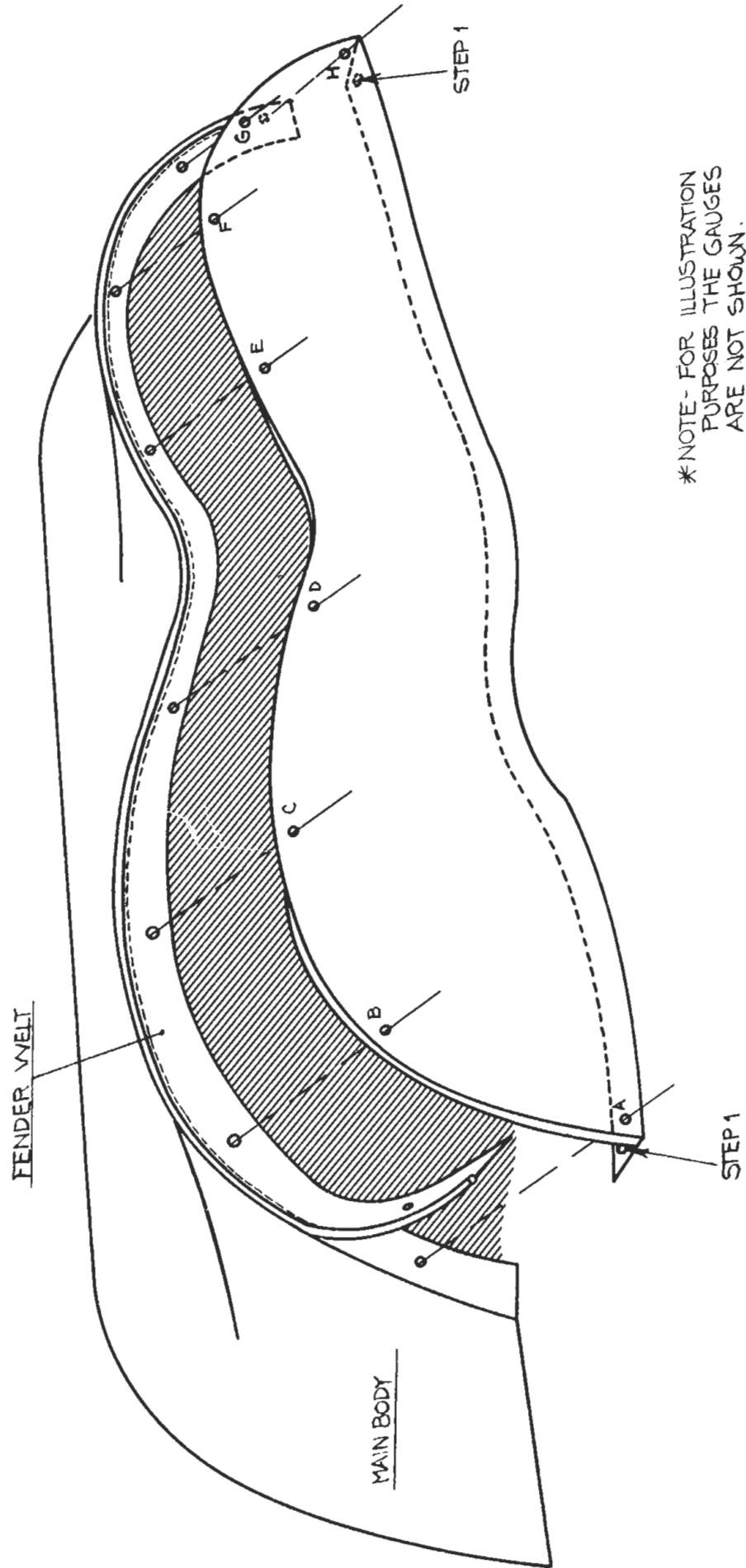

*NOTE- FOR ILLUSTRATION PURPOSES THE GAUGES ARE NOT SHOWN.

17 MOUNTING THE HOOD

Fiberfab Parts Required:

M531 Hood Hinges and Latches
M551 Chrome Hood Strip
M555 Bolt Kit
MX194 Contact Cement

Tools and Materials Required:

Sabre Saw
File
Electric Drill
Drill Bit: 1/8"
Scribe
Wrench
Screwdriver

1. Trim the hood to within $\frac{1}{4}$ " of the finish scribe line. The hood requires trimming for an exact fit. Begin by fitting the rear of hood. File the rear edge until the hood rests snugly against the bead of the cowl strip.
2. File the front edge of the hood, to obtain the proper length. The front edge of the hood should rest on the upper flange of the grille shell.
3. File the sides of the hood, so that they rest against the upper flanges of each hood side, and the edge of the hood meets the upper edge of the hood side. Note: File the hood side lightly and check the fit of the hood against the sides frequently, to prevent over-trimming.
4. Locate the center of the hood, by measuring the midpoint between the two raised windshield wipers and the midpoint at the top of the grille shell. Mark the center line on the hood.
5. Position the hood strip end brackets against each edge of the hood, at the center line. Scribe a square notch at each end onto the hood, $\frac{3}{4}$ " deep and the width of the raised part of the bracket. Cut out the two square notches. (Fig. 17.1)
6. Position one end bracket into the notched area, and glue it onto the hood from the under side. (Fig. 17.1)
7. Insert the hood strip into the bracket. Slide the other end bracket over the hood strip, and glue it onto the hood from the under side.
8. Position the hood hinges on the driver side of the car as shown in Fig. 17.2. The hinge pin should align with the seam between the hood and the hood side. Using the hinge as a template, scribe through the mounting holes onto the hood and hood side. Drill out the mounting holes, using a $\frac{1}{8}$ " drill bit. Secure the hinges to the hood

and hood side, using 10-32 x 1½" bolts and nuts.

9. Position the lower half of the hood latch onto the passenger hood side, so that the edge of the latch is aligned with the upper edge of the hood side, as shown in Fig. 17.2 Detail. Using the latch as a template, scribe the mounting holes onto the hood side. Drill out the mounting holes, using a 1/8" drill bit. Secure the latch to the hood side, using the longer 10-32 x 1½" bolts and nuts.
10. Position the upper half of the latch on the hood so that, when the latch is secured, the hood is pulled tight to the passenger hood side. using the latch as a template, scribe the mounting holes onto the hood. Drill out the mounting holes, using a 1/8" drill bit. Secure the upper half of the latch to the hood, using the short 10-32 x 1½" bolts and nuts.

CHROME HOOD STRIP FIG. 111

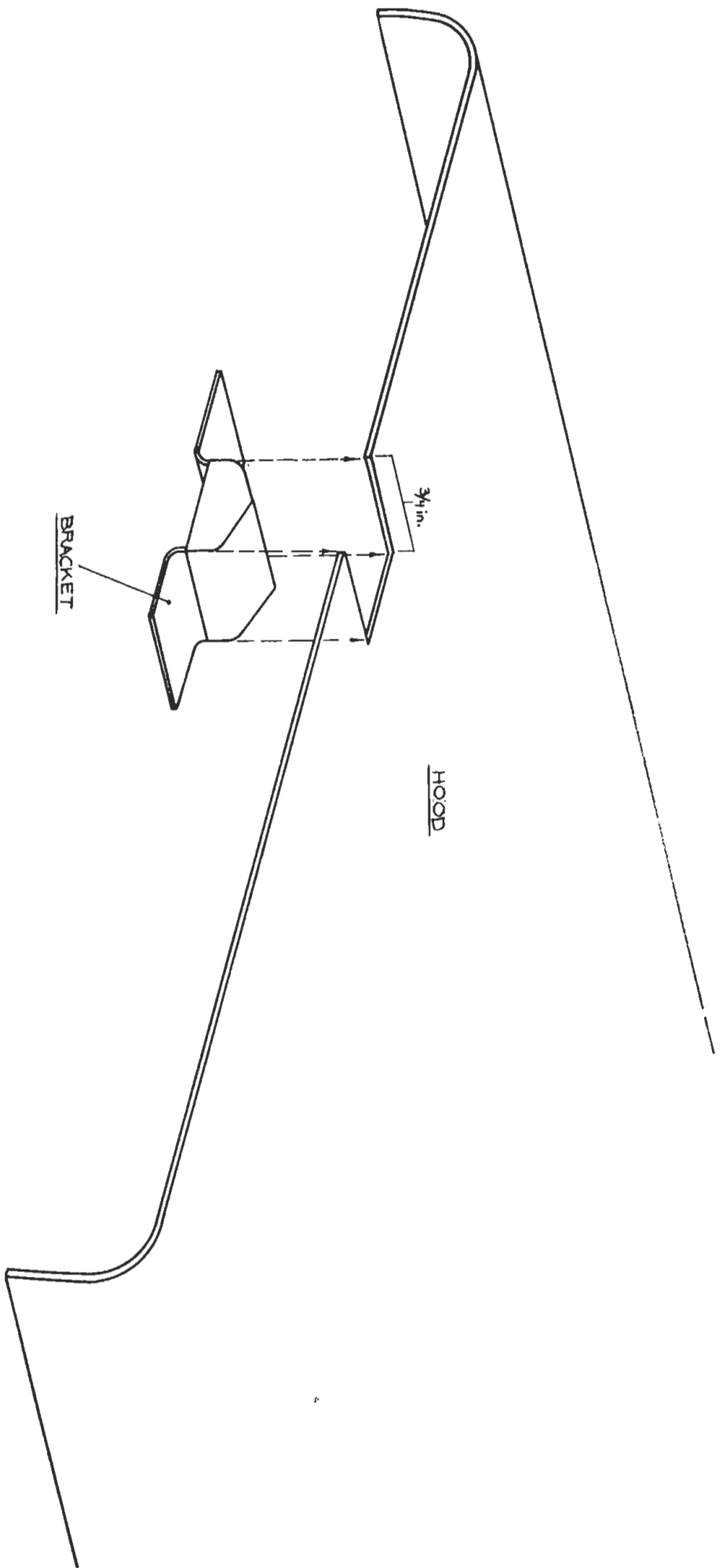

MOUNTING HOOD FIG. 17.2

DRIVER'S SIDE
STEP 8 - DRILL 12 PRESCRIBED HOLES AND
BOLT HINGES TO HOOD & HOODSIDE

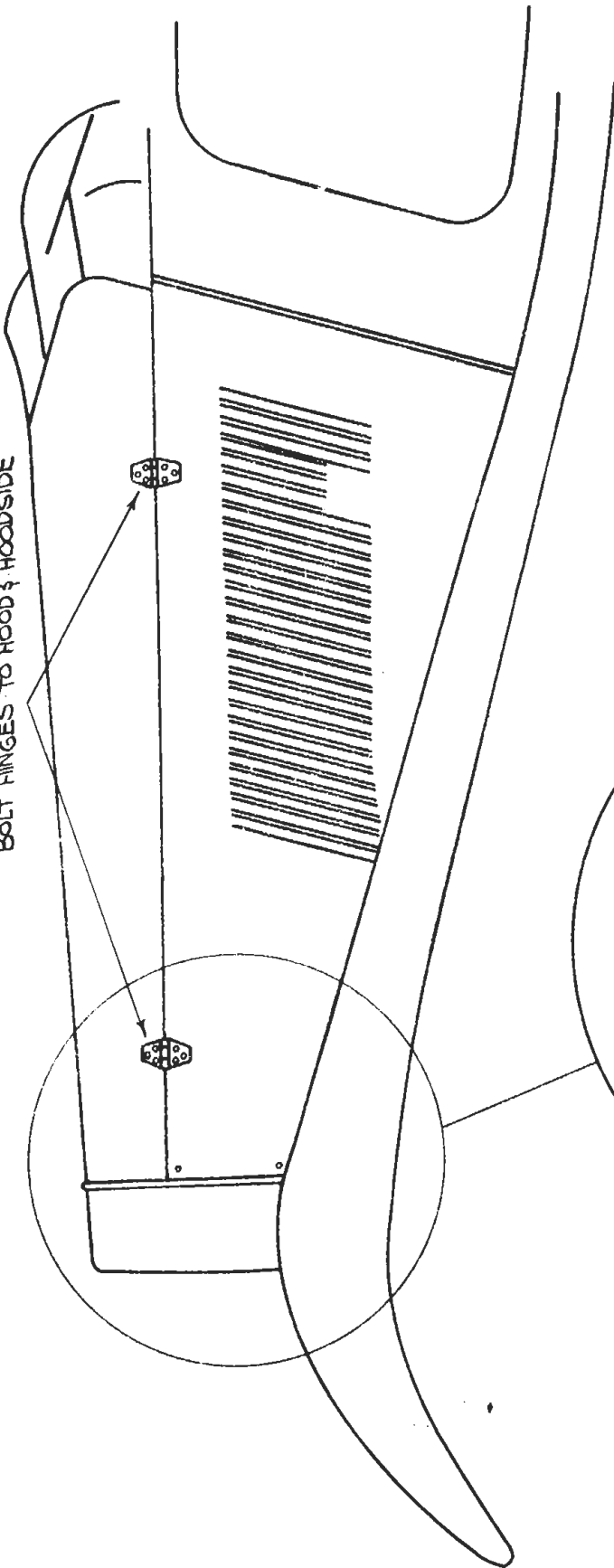

PASSENGER'S SIDE
STEPS 9-10

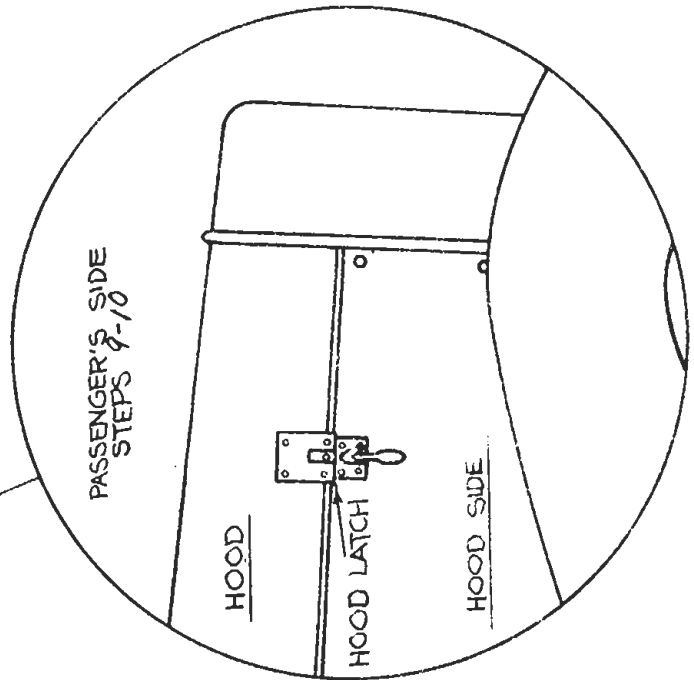

18. WINDSHIELD

Fiberfab Parts Required:

M512a Windshield
M512b Windshield Frame
MX194 Contact Cement
M555 Bolt Kit

Tools and Materials Required:

Screwdriver
Wrench
Rubber Mallett
Hack Saw
Electric Drill
Drill Bits: 5/16", 1"

1. Glue the thin rubber gasket included in the windshield frame kit around the four sides of the windshield. Spread contact cement on the edge of the glass and press the smooth side of the gasket around the edge of the glass.
2. Slide the gasket-lined glass into the frame, application of a lubricant (e.g., rust penetrant) to the windshield and gasket will facilitate this operation. (Fig. 18.1)
3. Slide the bottom edge of the frame onto the main frame, and pound the frame piece lightly into place, with a rubber mallett. (Fig. 18.1)
4. Adjust the thin rubber gasket (around the windshield glass) into the frame, so that only one lip folds over the outside of the frame. Press the gasket underneath the frame edge using a thin screwdriver. Note: Do not touch the glass surface with the screwdriver, to prevent scratching or breaking the glass.
5. Press the large rubber gasket onto the bottom of the frame, so that the larger flange is toward the outside of the frame, and the smooth side will mount flush on the main body section. (The outside of the frame has the larger edge.)
6. Slide the windshield onto the main body, so that the edges of the frame fit against the raised flat area on each side of the main body. CAUTION: Glass can crack. To help prevent cracking, two people should perform this operation. With one person on each side of the car, ease the windshield and frame evenly onto the main body. (Fig. 18.2)
7. Scribe any excess frame at each side, so that the frame legs are even with the raised areas. Remove the frame from the main body. (Fig. 18.2)

8. Cut the excess frame along the scribes made in Step 7. Drill two bolt holes in each leg of the frame, $1\frac{1}{2}$ " and $2\frac{1}{2}$ " from the bottom edge of the frame legs. Use a $\frac{5}{16}$ " drill bit. Re-drill through the top of the bolt holes, using a 1" drill bit, to countersink the holes so that they will accommodate the bolt heads. (Fig. 18.2)
9. Slide the windshield back onto the main body. Bolt the windshield into place at the lower bolt hole only, at each side. Adjust the angle of the windshield until the measurement from the top of the frame to the back edge of the main body equals 52". Bolt the frame to the body at the top two bolt holes. Use $\frac{1}{4}$ -20 X $1\frac{1}{2}$ " *Phillips*. (Fig. 18.2)

WINDSHIELD F/G. 18.1

* NOTE - GLUE THIN RUBBER GASKET AROUND GLASS BEFORE INSERTING INTO FRAME.

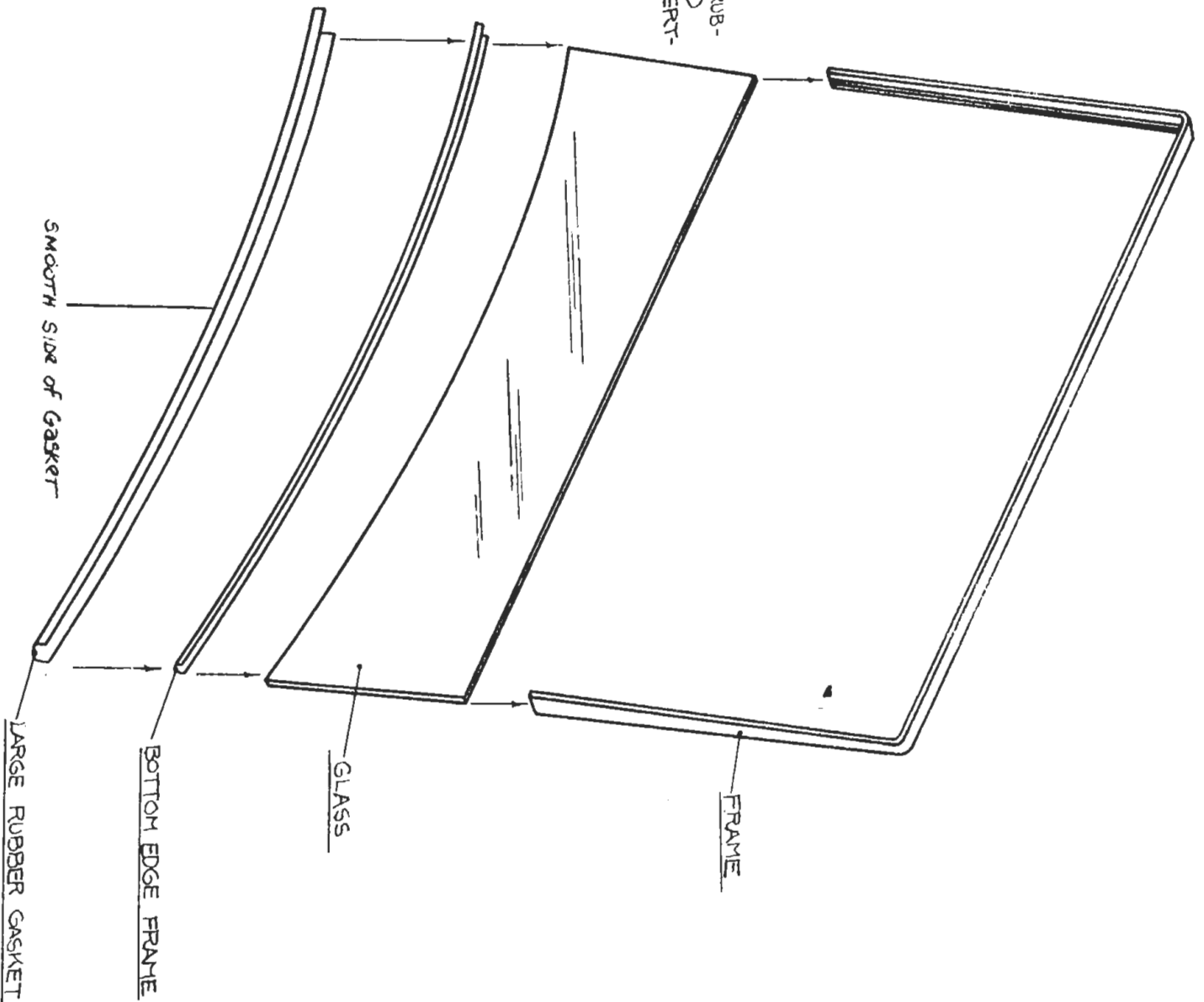

WIND SHIELD FIG. 18.2

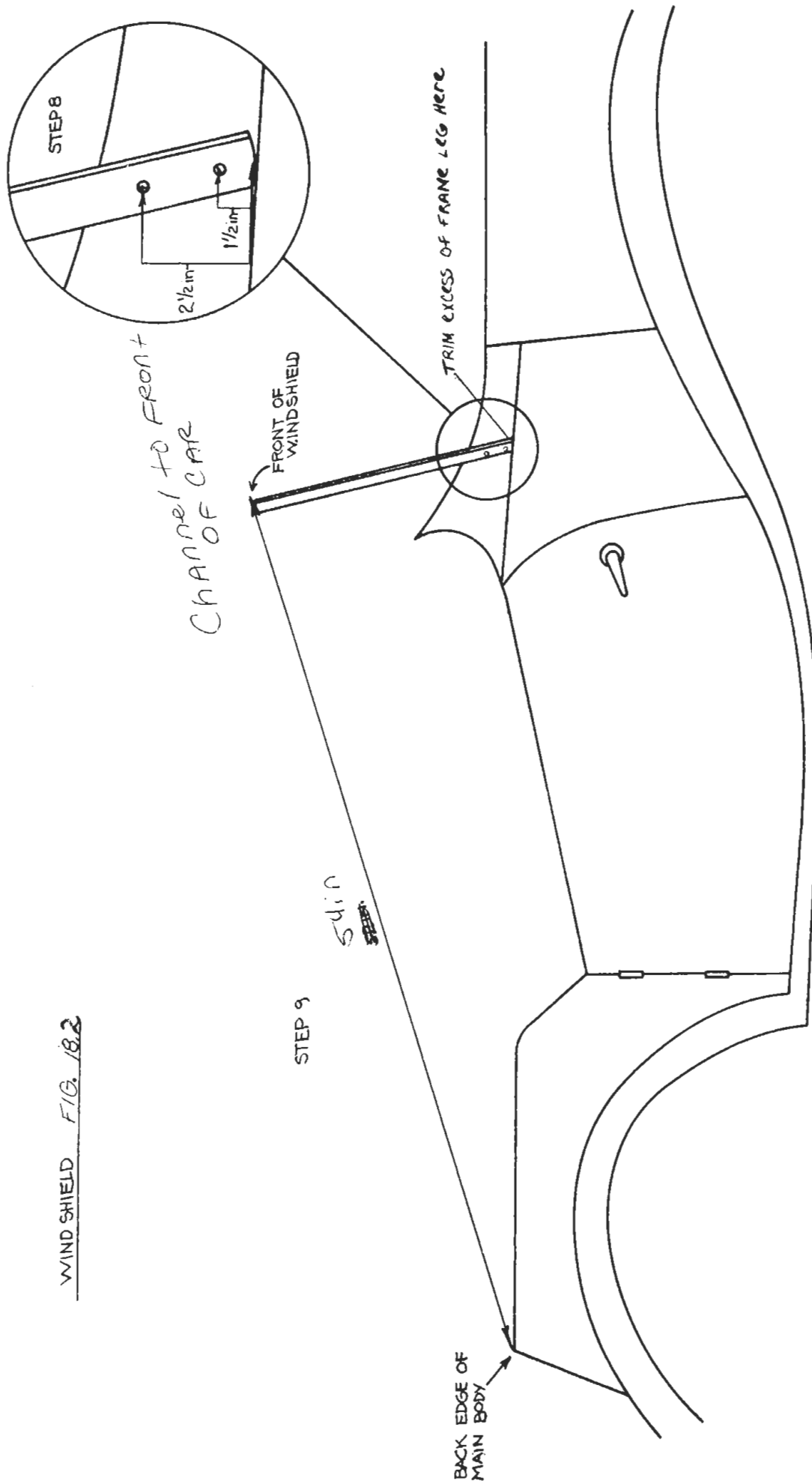

19 WIND WINGS

Fiberfab Parts Required:

M541 Wind Wings

Tools and Materials Required:

Hack Saw
Electric Drill
Drill Bit: 5/32"

1. Disassemble the wind wing and brackets, by removing the bracket nuts and bolts.
2. Enlarge each bracket indentation (where the brackets fit over the windshield frame). Use a hack saw, or drill with a 5/32" drill bit, placing the bit horizontally into the indentation.(Fig. 19.1)
3. Re-attach the wind wing to the brackets. Position the brackets against the windshield frame so that the top bracket is 4" from the top edge of the windshield frame. Note where the bolt holes in each bracket are, and scribe the inside edge of the windshield frame at the points where the bolt holes will be. Remove the wind wing from the windshield frame. (Fig. 19.1).
4. Drill the windshield frame from the inside toward the outside, at the points marked in Step 3. Use a 5/32" drill bit.
5. Position the wind wing in the windshield frame, aligning the bolt holes in the brackets with the bolt holes drilled in the frame.
6. Insert the allen screws included with the wind wing assembly into each bolt hole, and tighten with an allen wrench, also included with the assembly.

BRACKET INDENTATION

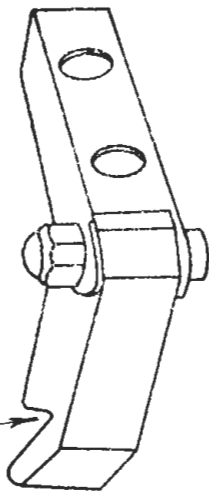

WIND WINGS FIG. 19.1

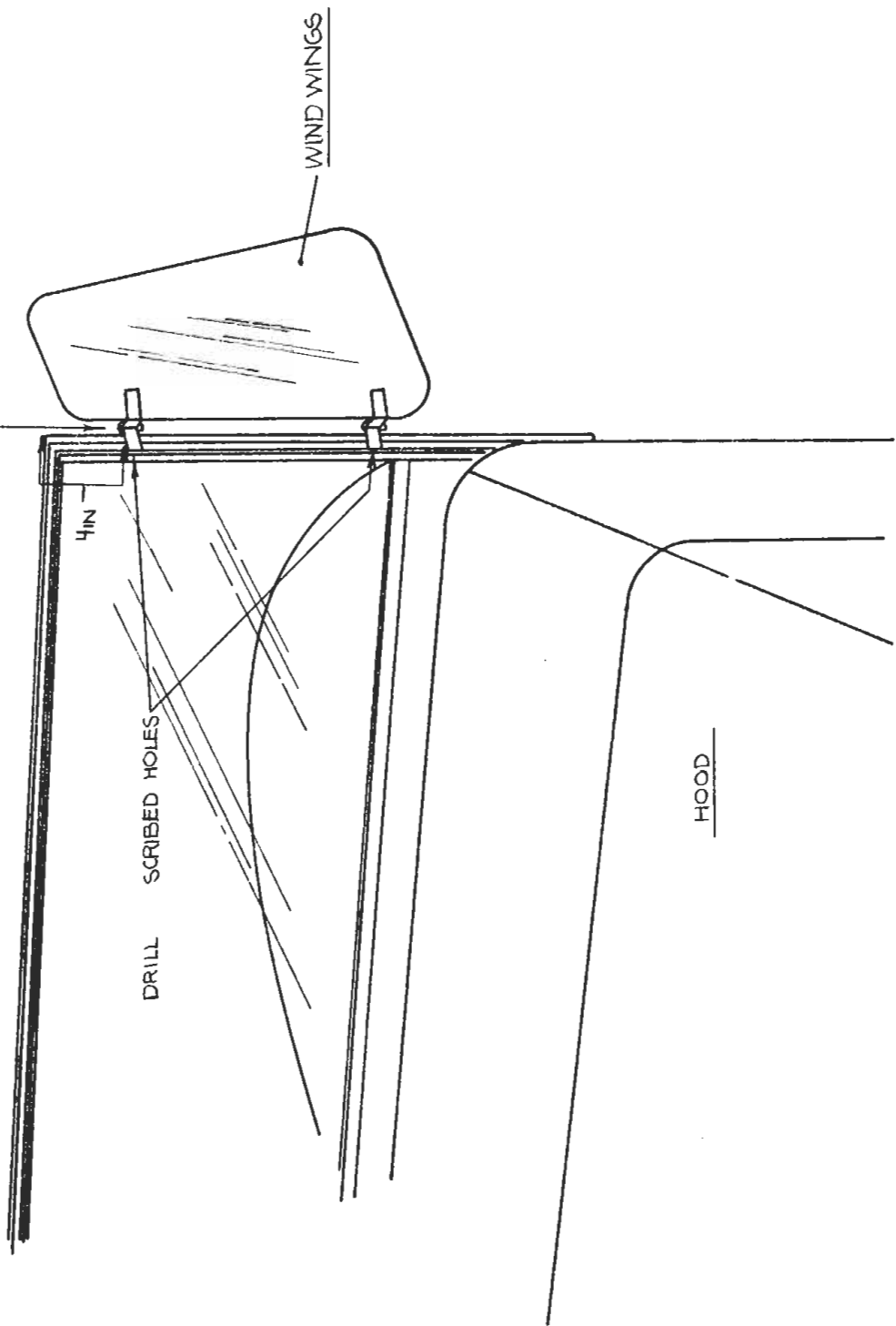

20 CONVERTIBLE TOP

Fiberfab Parts Required:

M522 Convertible Top

Tools and Materials Required:

Screwdriver
Electric Drill
Drill Bit: 1/8"

1. Position the anchor bracket (on the convertible top support bars) against the inside of the main body, so that from the bottom edge of the console to the middle of each bracket equals 25". (Fig. 20.1)
2. Using the brackets as a template, drill two bolt holes on each side of the main body. Use a 1/8" drill bit. Screw each bracket to the main body, using the screws included with the brackets. (Fig. 20.1)
3. Remove the center screw from each anchor bracket. Align the bolt holes in the top support bars with the holes in the brackets. Screw the top frame to the brackets. (Fig. 20.1)
4. Pull the front of the top forward, and insert the front edge into the windshield frame. (Fig. 20.1)
5. Pull the back of the top to the rear of the main body, with the rear window zipped closed. Locate the position for the center snap, and drill through the rear of the body at this point, using a 1/8" drill bit. The top should be pulled taut at this point. (Fig. 20.2)
6. Screw the snap into the main body, and snap the back to the body. Repeat Steps 5 and 6 for each of the ten remaining snaps (A - E, right and left) at the rear of the top. (Fig. 20.2)
7. Locate the position for the two upper corner snaps at the front of the top, on the inside of the windshield frame. Drill, and attach snaps. (Fig. 20.3)
8. Zip in the side curtains. Locate the positions for the three forward snaps on each side (F, G, and H). Drill and attach the snaps on the outside of the windshield frame. The upper corner snap of each side curtain should fit underneath the upper edge of the top. (Fig. 20.4)

9. Locate the position for the four back snaps on each side of the top (I, J, K, and L). Attach the snaps (Fig. 20.4).
10. Locate the position for the seven lower side curtain snaps on each side (M - S). Attach the snaps. (Fig. 20.4) Note: The lower edge snaps for the side curtains will be screwed into the outside of the door.
11. Unzip the rear window. Tighten the ribbons on either side, and pull them toward the back of the main body. The clasp at the end of each ribbon should extend to within $\frac{1}{4}$ " of the body. (Fig. 20.5)
12. Position the two rear brackets on each side at the back of the main body, $\frac{3}{4}$ " from the outer edge and in line with the zipper (Fig. 20.5). Scribe the bolt holes for each bracket and drill, using a $\frac{1}{8}$ " drill bit.
13. Screw the brackets into place, using screws included with the bracket assembly. Hook the ribbons onto the brackets, and adjust the length of the ribbons so that the top is pulled tight.

CONVERTABLE TOP FIG. 201.

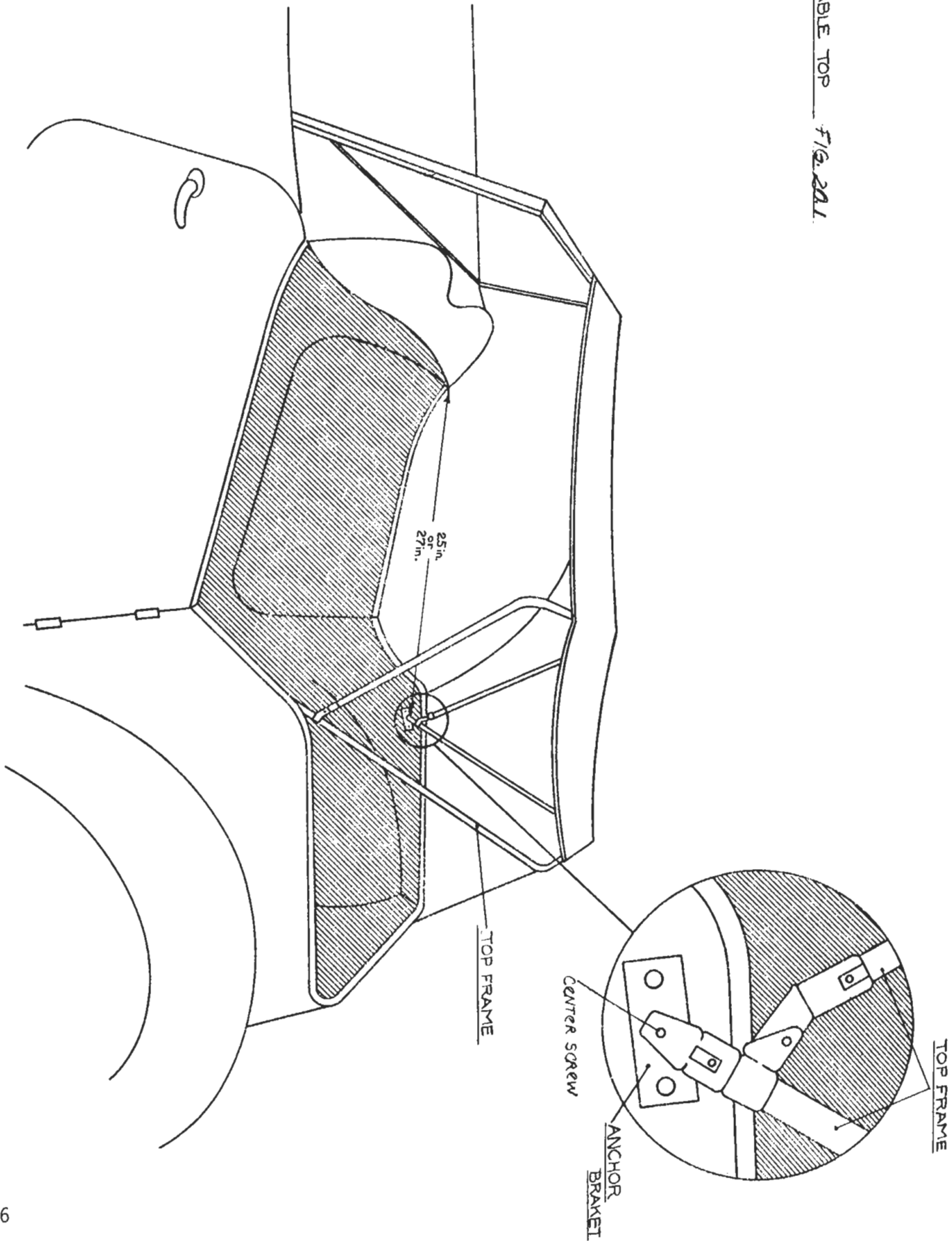

CONVERTABLE TOP - FIG. 2A2

* NOTE - SNAP E IS SHOWN ON NEXT ILLUSTRATION

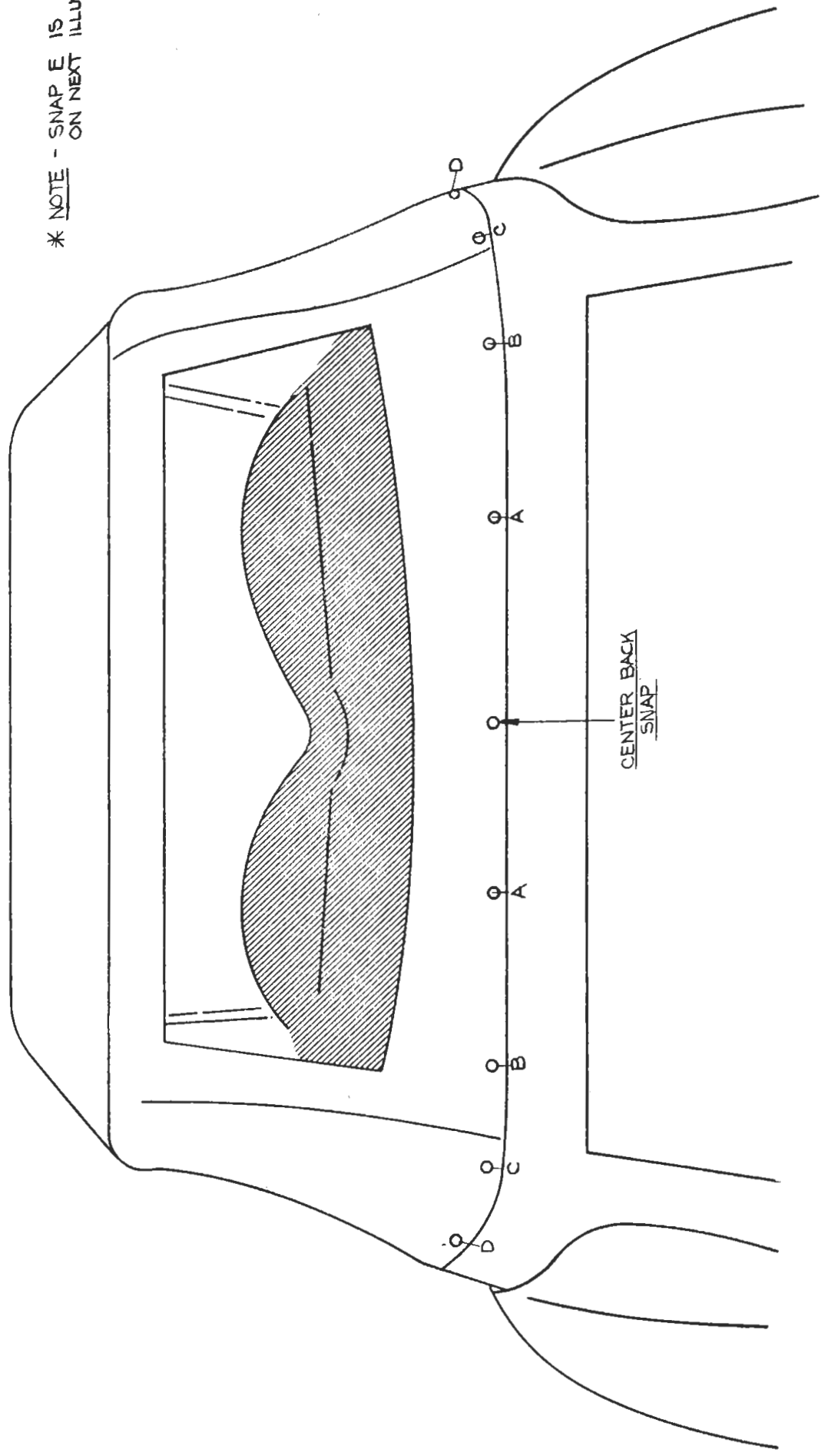

CONVERTIBLE TOP - FIG. 20.5

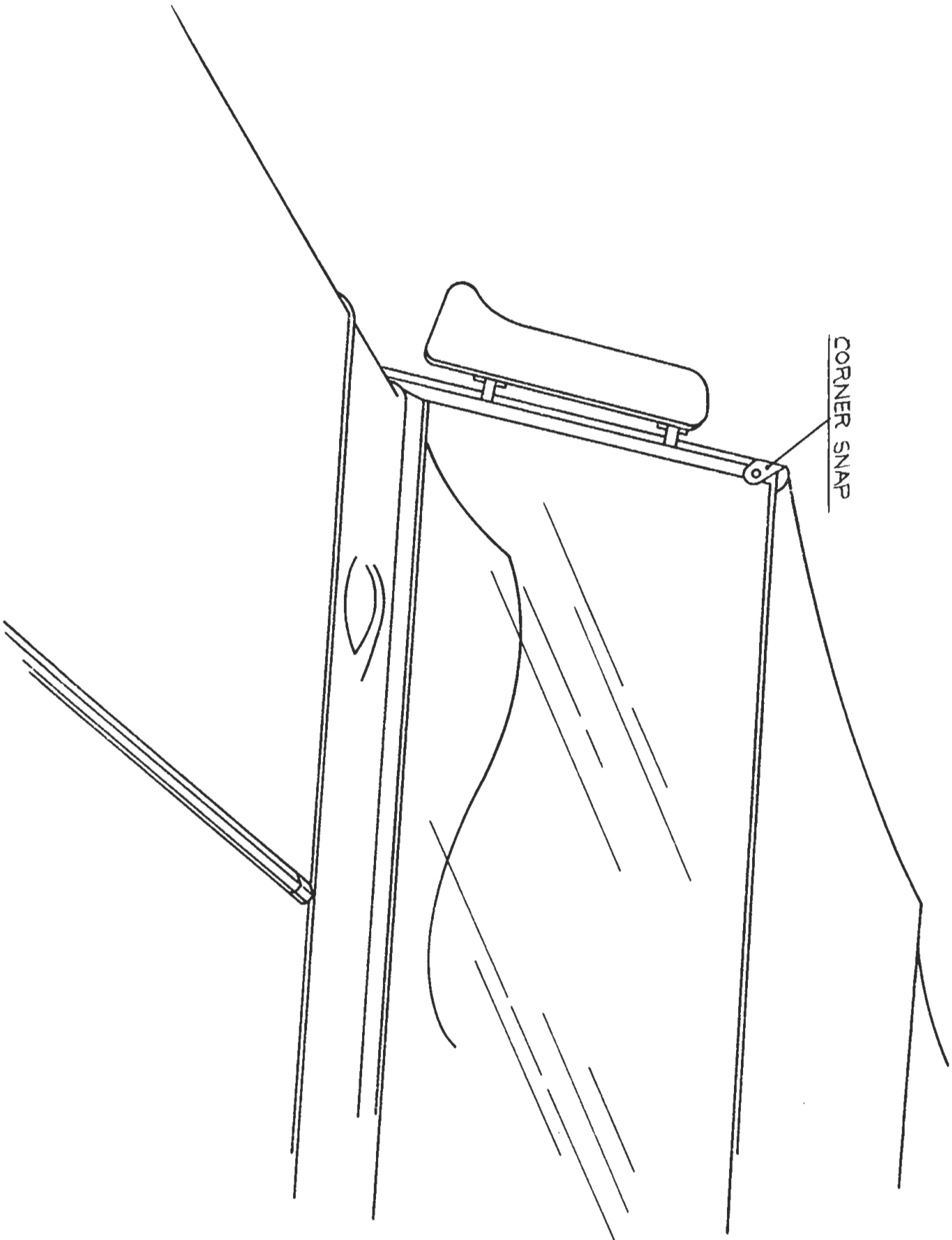

CONVERTABLE TOP - FIG. 204

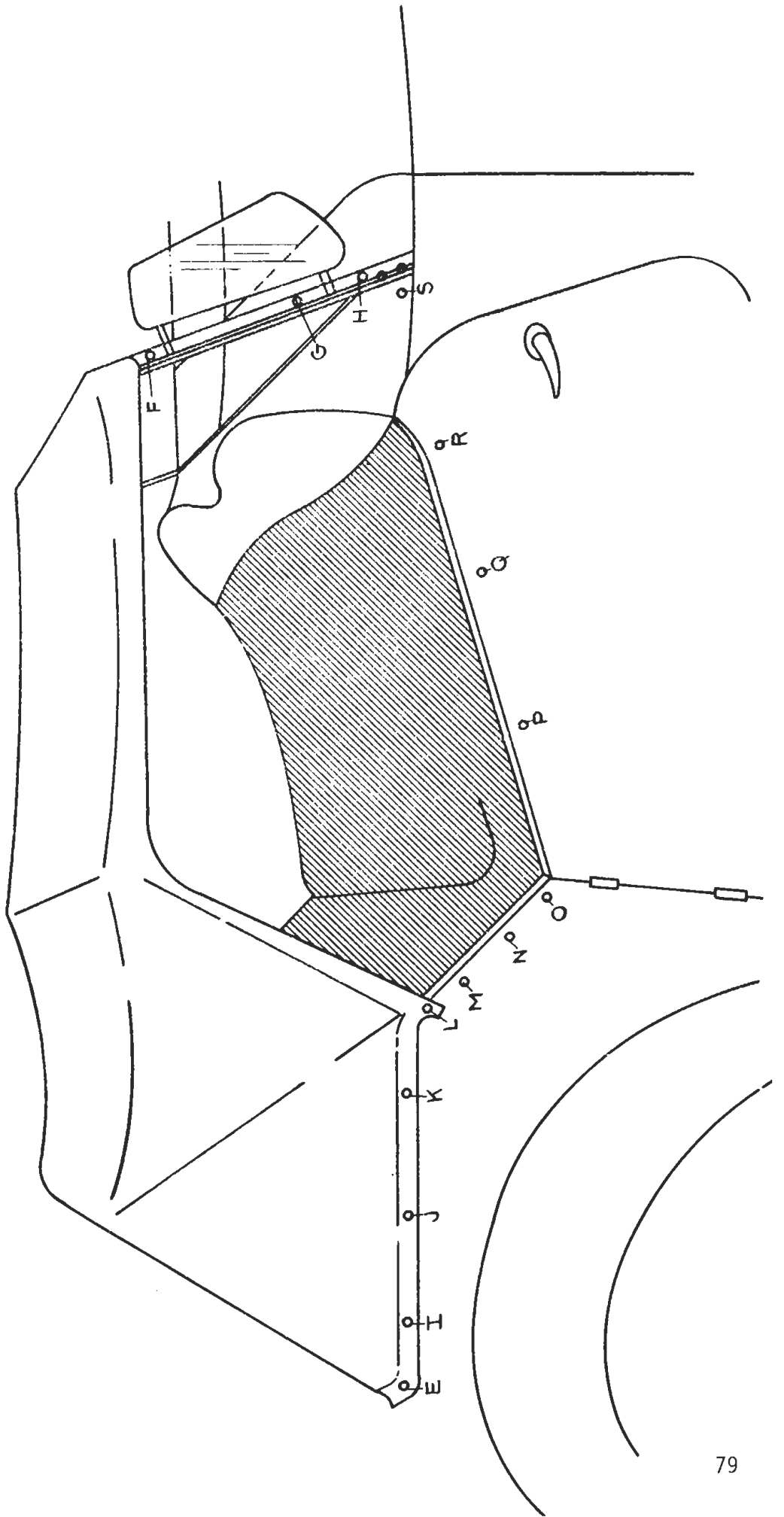

CONVERTIBLE TOP FIG. 20.5

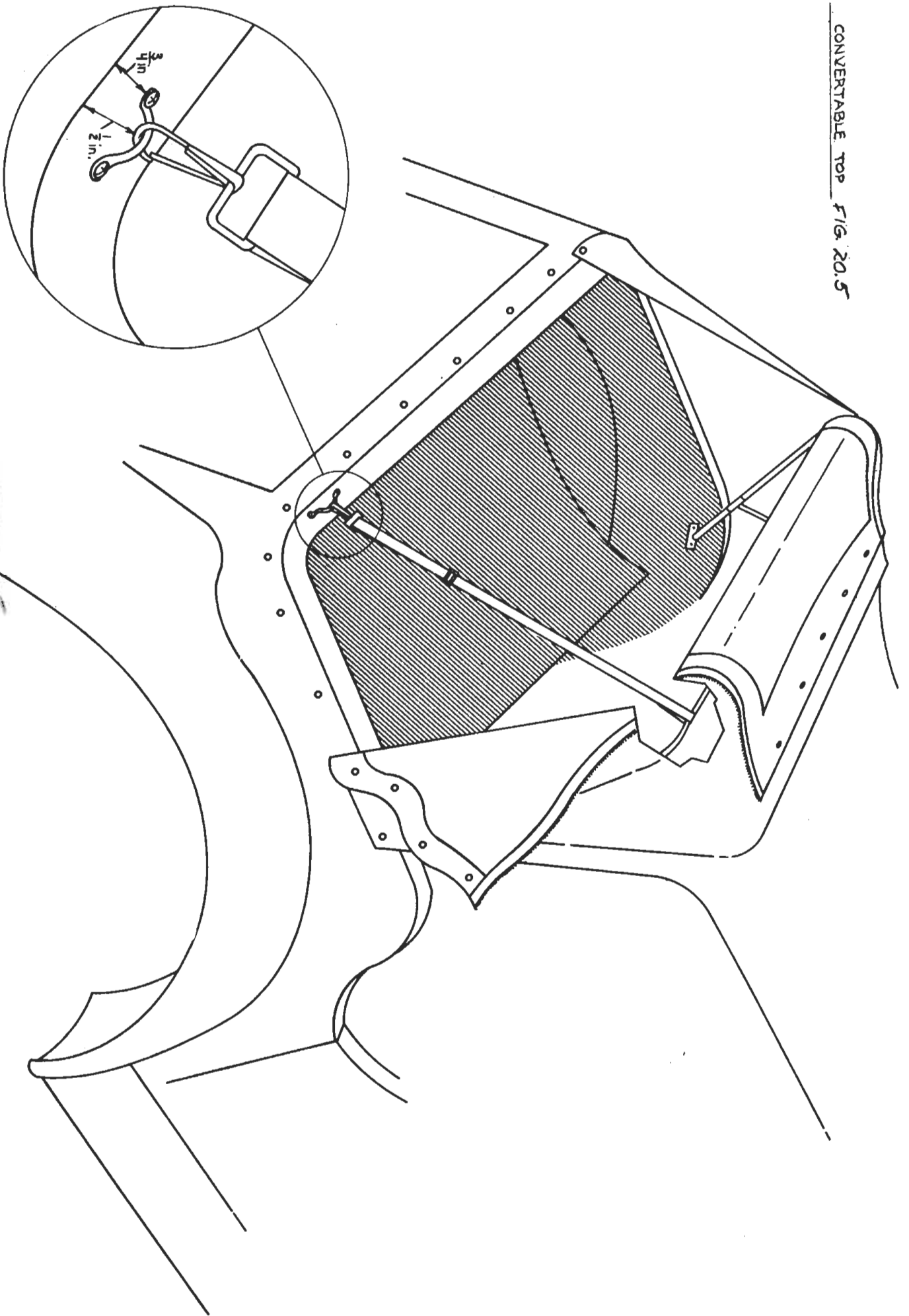

21 TRIM - BADGES, ACCESSORIES, ETC.

Fiberfab Parts Required:

M532	Running Board Trim
M535	Radiator Cap
M536	Motometer
M544	Union Jack Side Markers
M548	MiGi Medallion
X172	Fog Light
MX194	Contact Cement
M542	Badge Bar
M525	Fender Mirrors

Tools and Materials Required:

Scribe
Sabre Saw
Screwdriver
Electric Drill
Drill Bits: 1/8", 5/32", 1/2"

A. Motometer and Radiator Cap

1. Remove the two screws from underneath the radiator cap.
2. Drill on the center point of the radiator cap, using a 1/2" drill bit.
3. Position the radiator cap on the top center of the grille shell. Using the radiator cap as a template, scribe the center hole onto the grille shell. Drill, using a 1/2" drill bit.
4. Insert the motometer base screw through the radiator cap and the grille shell. Secure the motometer from underneath the grille shell, using the nuts included with the motometer.

B. Running Board Trim

1. Position the trim strips on the running boards, 1 1/2" from the running board separators, 2" apart and 1 1/2" from the inside edge of the running board. (Fig. 21.1)
2. Remove the backing from the strips and press the self-adhesive strips into place. Remove the backing from the tips and press them into place at the ends of the each strip. (Fig. 21.1)

C. Badge Bar

1. Position the badge bar onto the front base of the grille shell, as shown in Fig. 21.2. Using the badge bar ends as a template, scribe the mounting holes onto the grille shell. Drill out the mounting holes, using a 1/8" drill bit. Drill through both the grille shell and the front fenders.

2. Bolt the badge bar to the grille shell and front fenders, using 10-32 x 1½" bolts and nuts. Included with the badge bar are two small headless screws. Insert these screws into the screw holes at each end of the badge bar, attaching the bar to the end stands.

D. Fog Light

1. Position the fog light at the driver's side front base of the grille shell, in front of the badge bar. Using the light as a template, scribe the two mounting holes onto the grille shell base. (Fig. 21.2)
2. Drill the mounting holes using a 5/16" drill bit. Bolt the fog light to the grille shell, using bolts included with the light assembly.
3. Centered directly behind the fog light, drill a hole with a 1/8" drill bit. The resulting hole will allow for wiring connections.

E. Badges

1. Attach the headless screws (included with the badge) to the back of the badge, and position the badge against the grille shell. Use the screws to scribe two bolt holes onto the grille shell inset.
2. Drill out the two holes scribed in Step 1, using a 5/32" drill bit. Place the badge on the grille shell and secure the bolts from inside, using the nuts and washers included with the badge. (See Fig. 21.3 for positioning.)
3. For attaching the badge to the badge bar, attach the headless screws to the back of the badge, and slide the Mount-a-Badge plate onto the screws. Secure the plate with the washers and nuts included with the badge.
4. Place the clip bracket onto the badge bar. Align the bolt holes in the clip with those in the plate. Tighten the clip using the nuts and bolts included with the Mount-a-Badge.

F. Medallion

1. On the back of the MiGi II Medallion, spread an even layer of contact cement. Place the medallion on the raised flat surface at the top front of the grille shell. Hold the medallion in place until the glue begins to set. (Fig. 21.3).

G. Union Jack Side Markers

1. Position each union jack 1" below the legs of the windshield frame on the sides of the main body. See Fig. 21.4 for positioning.
2. Secure the union jack to the main body, using the screws included with the union jacks.

H. Fender Mount Mirrors

1. Position the mirror gasket approximately 1" directly behind the front running light. Using the gasket as a template, scribe the mounting hole onto the front fender. (Fig. 21.5)
2. Drill out the mounting hole, using a 5/16" drill bit. Insert the mirror bolt through the gasket and the front fender. Secure the mirror in place from underneath the fender, using the nuts from the mirror assembly. The mirror should curve out, away from the body. (Fig. 21.5)

RUNNING BOARD TRIM FIG. 21.1

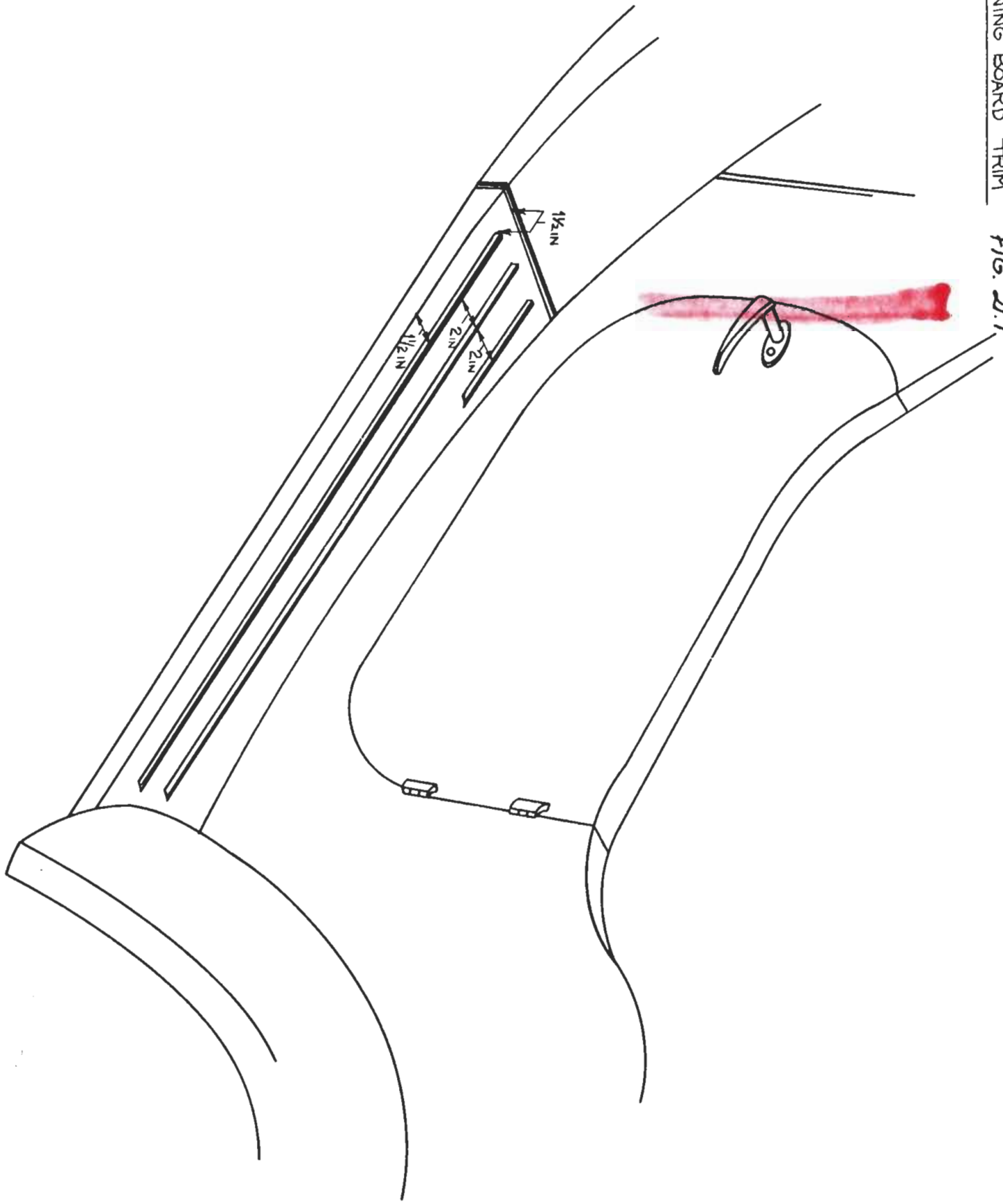

MOUNTING GRILL SHELL FIG. 242

R96
64
AS

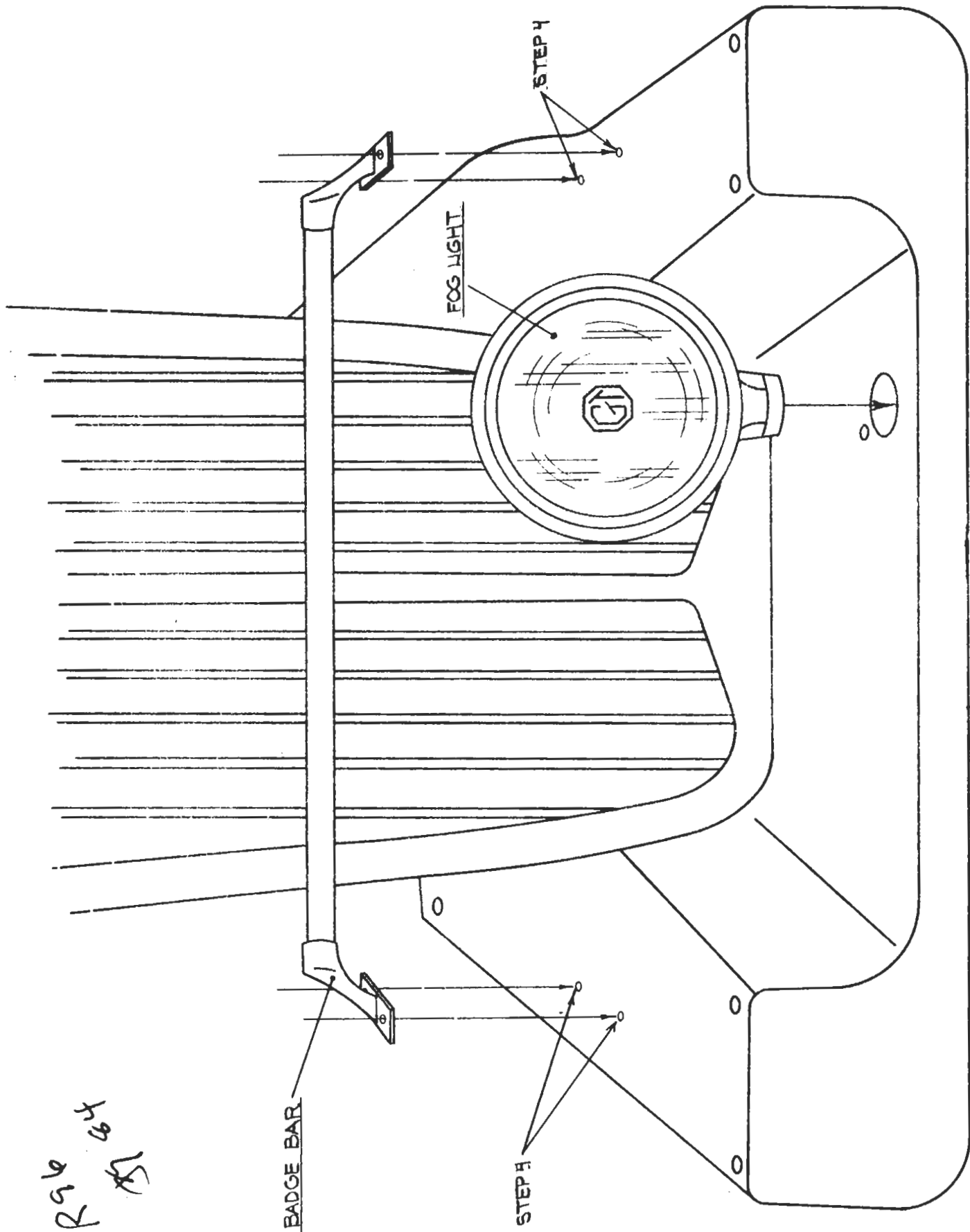

MEDALLION & BADGES FIG. 21.3

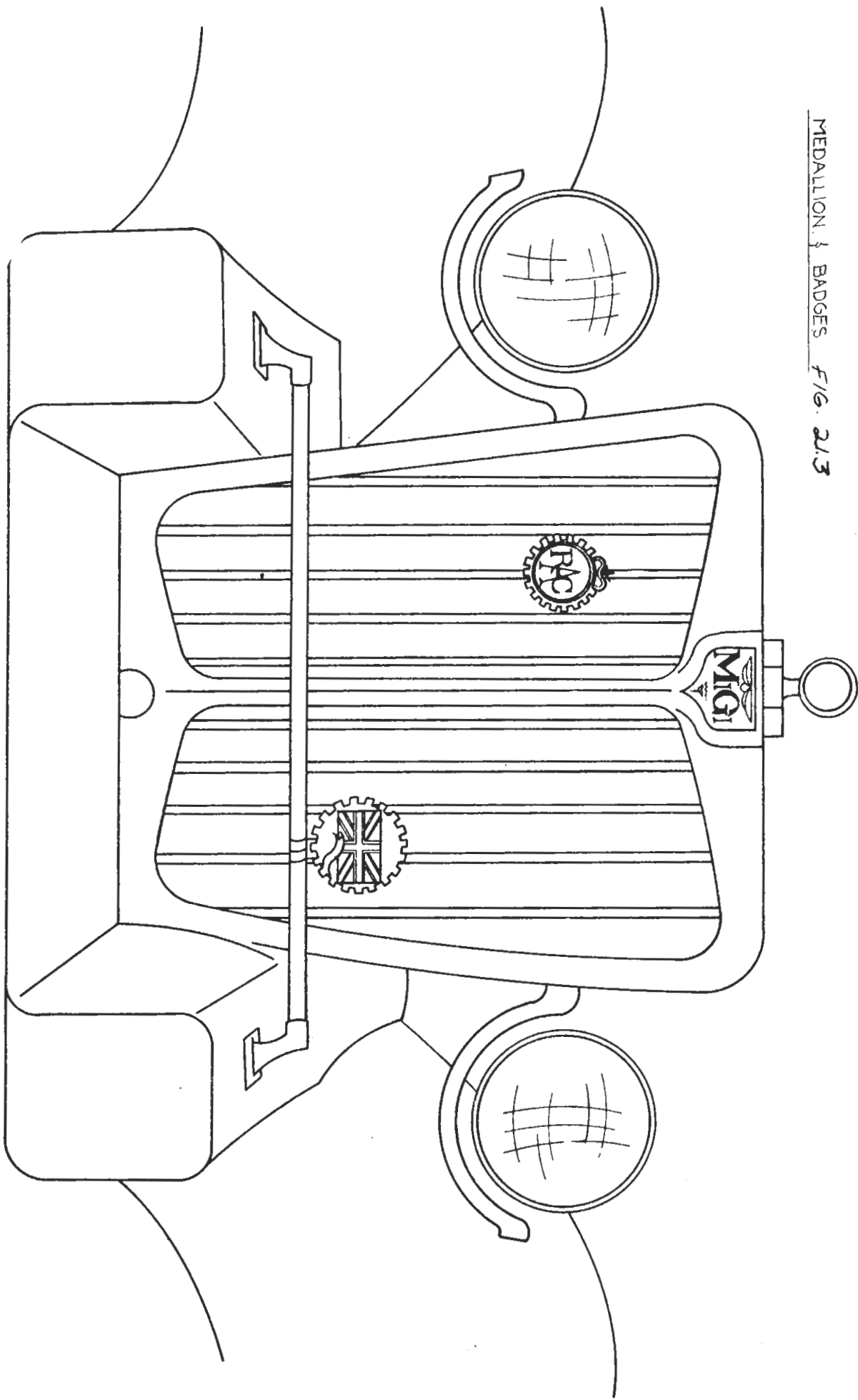

UNION JACK FIG. 21.4

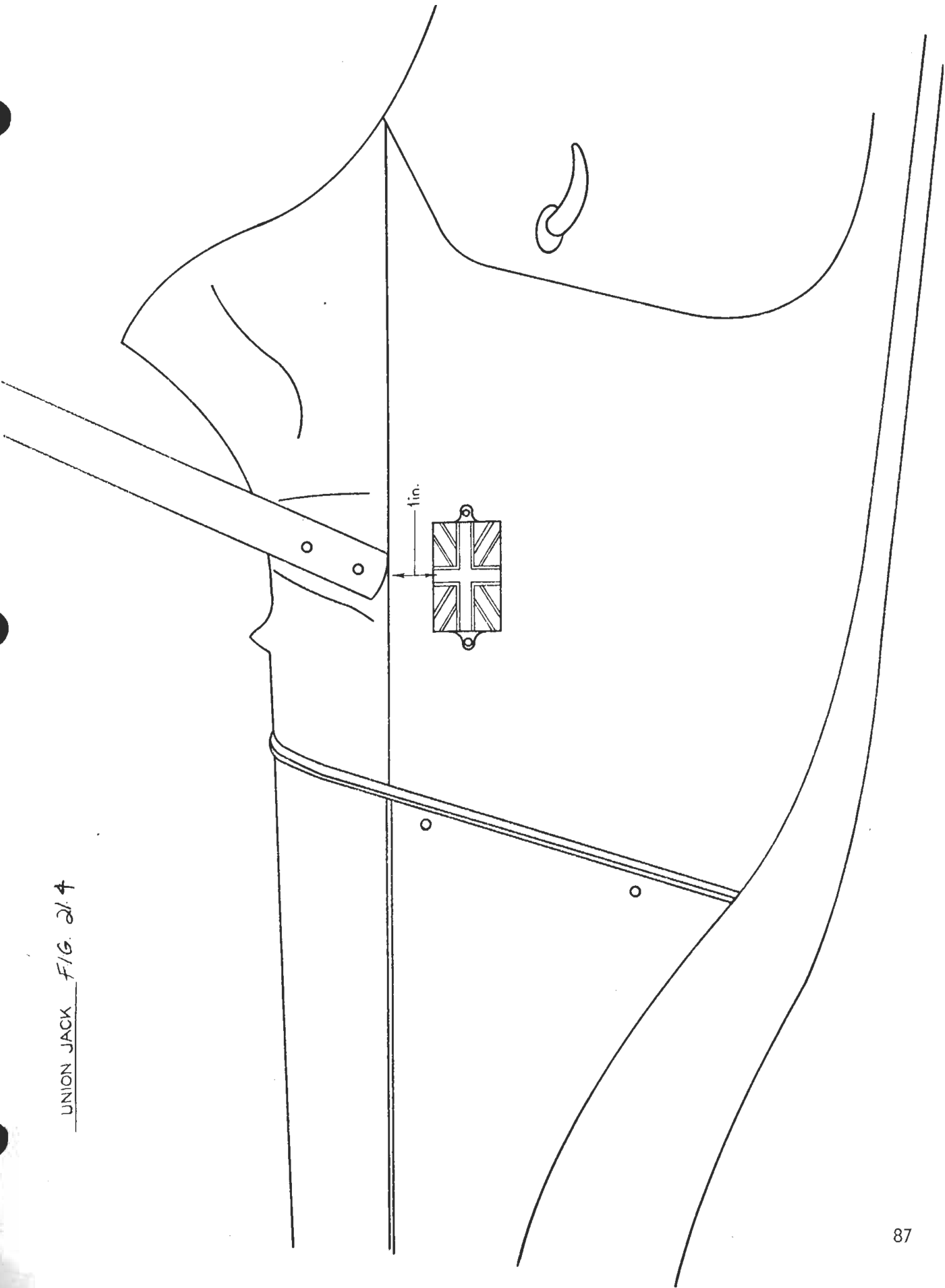

MOUNTING FENDER MIRRORS FIG. 21.5

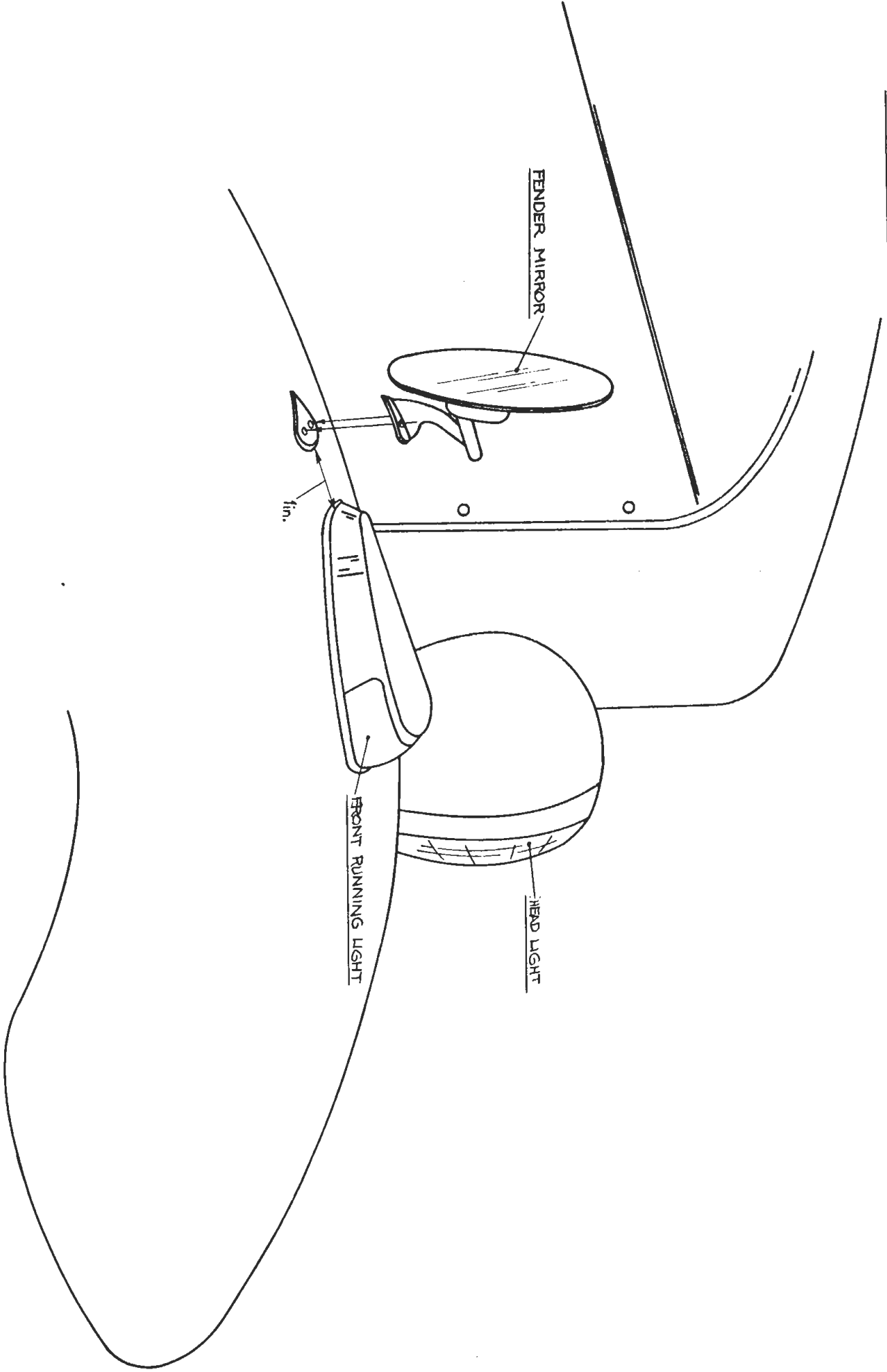

22. FRONT BUMPERS

Fiberfab Parts Required:

M523 Front Bumper Assembly
M524 Overriders

Tools and Materials Required:

Wrench
Electric Drill
Drill Bit: 7/16"

1. Position the front bumper face bar against the inside of the front bumper, placing the square spacers between the bumper and the face bar at bolt holes. Place the large S-brackets over the face bar. Bolt the brackets, bumper, and the end of the S-brackets together, at each end, using the chrome-headed bolts included with the bumper assembly (Fig. 22.1)
2. Bolt the overriders to the bumper and brackets, at the two inner side bolts. The bolt runs from the overrider through the bumper, face bar, and front part of the S-bracket. (Fig. 22.1)
3. Drill out the prescribed hole in each side of the grille shell at the front base. Use a 7/16" drill bit (Fig. 22.1).
4. Insert the bolts through the back part of the S-bracket, the small metal cylinder spacers, and the washers, and position the bumper onto the grille shell. Place the Z-brackets behind the grille shell onto the bolts, with the larger end at the rear pointing in toward the center of the car. Secure the bumper to the grille shell. The Z-brackets will be attached to the I-beams of the chassis at a later step. (Fig. 22.1)

MOUNTING THE FRONT BUMPER FIG. 22.1

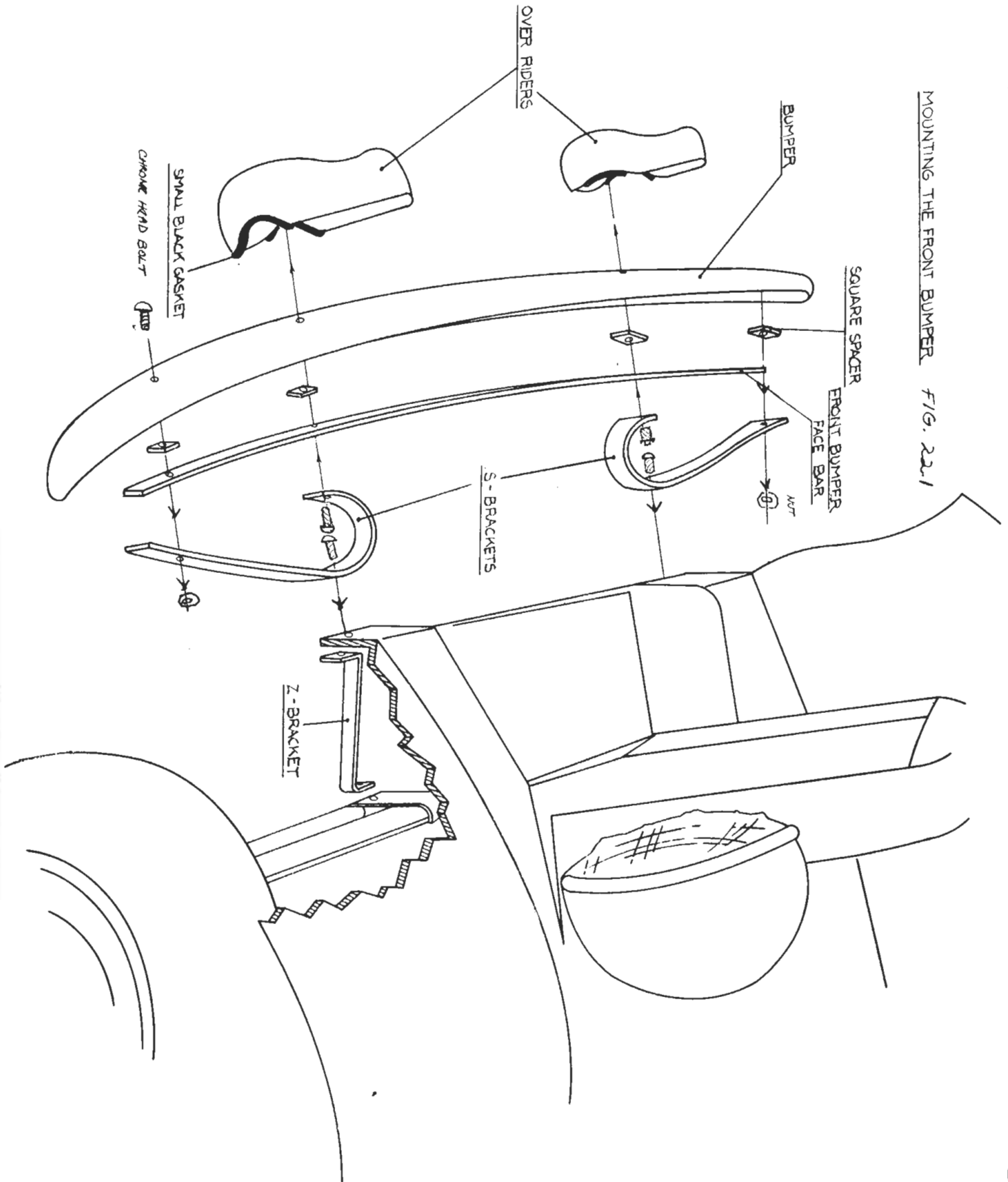

23 ENGINE COVER

Fiberfab Parts Required:

M513 Fenderwelt
M552 Spare Tire Cover
(from convertible top kit)
M554 Engine Cover Hinge
(Piano Hinge)
M555 Bolt Kit

Tools and Materials Required:

Scribe
Electric Drill
Drill Bits: 13/64" - 5/16"
Pop Rivet Gun
Scissors

1. Position the piano hinge on the upper mounting flange of the engine cover. The hinge pin should be level with the upper edge of the engine cover, and $\frac{1}{4}$ " from each side edge (Fig. 23.1). Using the hinge as a template, scribe mounting holes onto the engine cover flange. Note: Because the hinge may be slightly bowed, hold the hinge in place along the top edge of the flange at the point of each scribe.
2. Cut a piece of fenderwelt 66" long. Glue the fenderwelt to the side and top flanges of the engine cover, notching the fenderwelt at corners and around bolt holes. The bead of the fenderwelt should just clear the edge of the Engine Cover.
3. Pop rivet the piano hinge to the top engine cover flange over the fenderwelt, using 3/16" x 5/8" pop rivets. (Fig. 23.1)
4. Position the engine cover with the piano hinge against the back of the main body. The top edge of the engine cover should be $1\frac{1}{2}$ " from the top edge of the main body. The side panel of the engine cover should be 7" from the center rib of each fender. (Fig. 23.2). Holding the engine cover in this position, lightly scribe the upper corner edges of the engine cover onto the main body.
5. Holding the engine cover in an open position against the main body, realign the opened piano hinge inside the scribes made in Step 4. Using the hinge as a template, scribe the two end mounting holes onto the main body. Drill the two corner mounting holes, using a 13/64" drill bit. Note: This operation is most easily performed by two people: one person holding the engine cover in position, the other person scribing the bolt holes.

6. Pop rivet each end of the piano hinge to the main body. With the engine cover closed, check the alignment of the engine cover against the main body. If the engine cover position requires adjustment, drill out one of the corner pop rivets and re-install until the alignment is correct.
7. With the engine cover open, drill out the remaining mounting holes in the main body, using the piano hinge holes as a guide for the drill bit. Use a 13/64" drill bit. Pop rivet the piano hinge to the main body.
8. Drill four bolt holes evenly spaced around the raised flange of the engine cover, where the spare tire mounts. (Fig. 23.2)
9. Open the engine cover, and position the spare tire onto the engine cover flange. The base of the engine cover flange is squared and should align with the squared lower edge of the spare tire. The notched upper edge of the engine cover flange aligns with the notches in the spare tire flange, to accommodate engine components. Using the drilled holes in the engine cover flange as a guide, scribe bolt holes onto the spare tire flange. Note: This operation is most easily accomplished by two people: one person holding the spare tire in place above the open engine cover, and one person scribing the mounting holes from beneath the engine cover.
10. Drill the holes on the spare tire flange which were scribed in Step 9, using a 5/16" drill bit. Secure the spare tire cover (included with the convertible top) over the spare tire, making sure that the cover is pulled taut.
11. Realign the spare tire over the engine cover flange, aligning the bolt holes and notched or squared edges. Bolt the spare tire to the engine cover, using 1/4"-20 x 1 1/2" bolts and nuts. Bolt from the underneath side of the engine cover to the inside of the spare tire, and do not bolt through the tire cover. (Fig. 23.2)

ENGINE COVER FIG. 23.

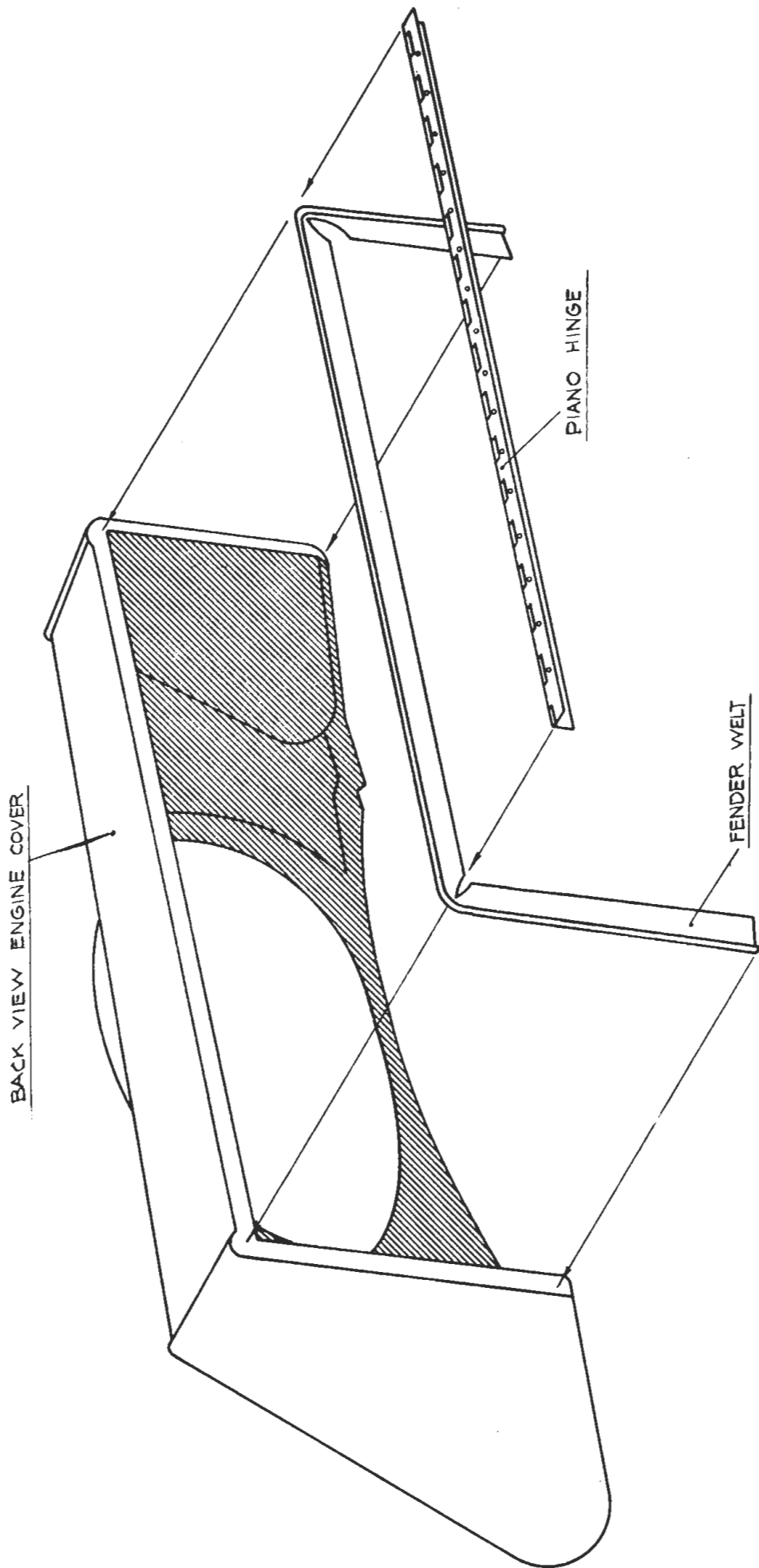

ENGINE COVER FIG. 23.2

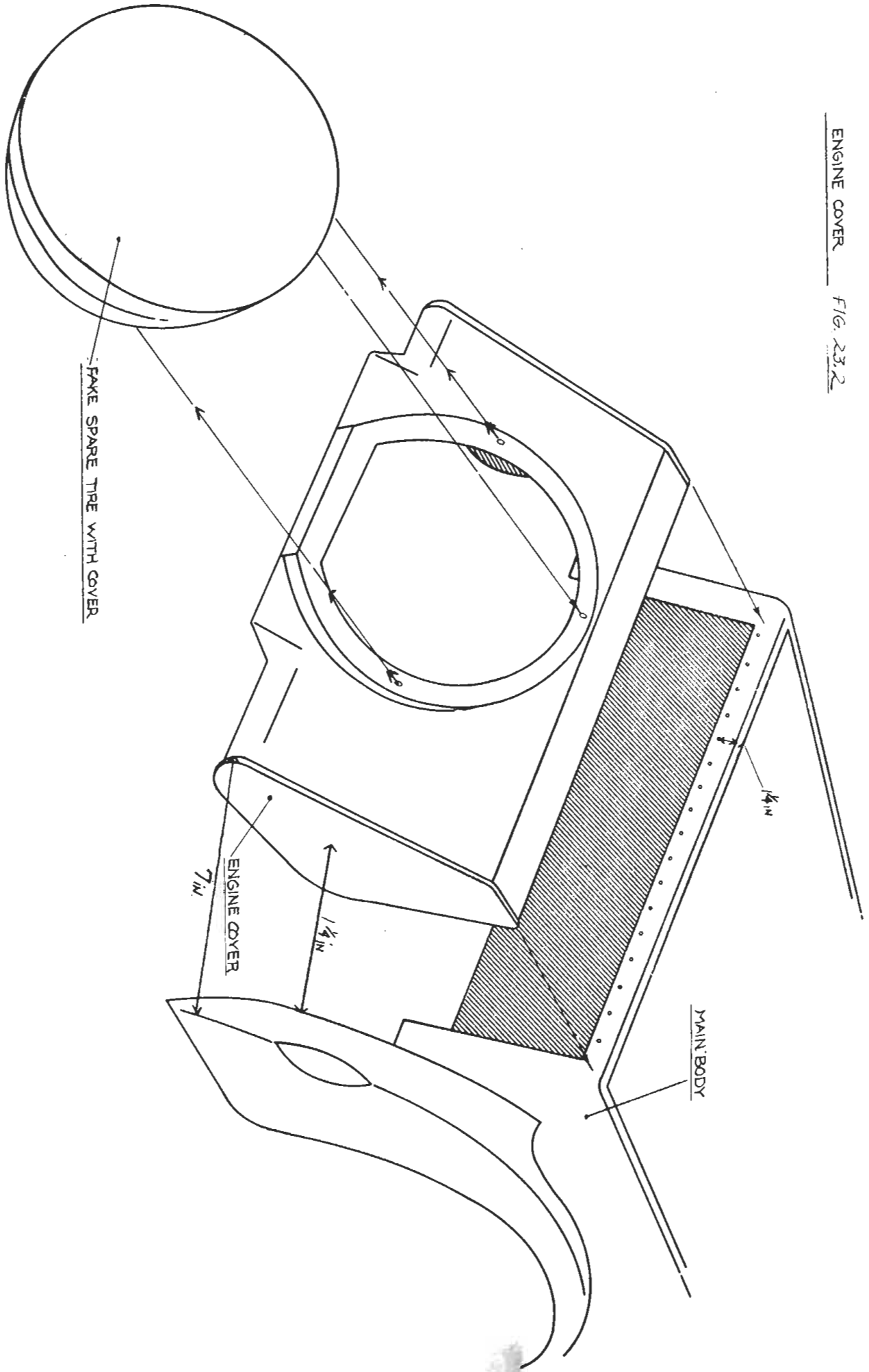

24 VOLKSWAGEN BODY DISASSEMBLY

Tools and Materials Required:

13 MM Ratchet
17 MM Ratchet
Wrenches
Screwdrivers

1. Disconnect the wire leading to the gas tank. Remove the bolts holding the gas tank and brackets, one on each side or two at the front and two at the rear.
2. Disconnect the breather hose from the gas tank. Lift up the gas tank, and clamp the hose underneath the tank to avoid spilling any gas left in the tank. Disconnect the hose from the chassis and remove the gas tank. Save the tank and all hoses for use in the MiGi II.
3. Unbolt the bracket of the brake fluid reservoir and unscrew the reservoir tank. Disconnect the rubber hoses and remove the reservoir. Save the reservoir, bracket, and tubes for use in the MiGi II.
4. Disconnect the wiring to the master cylinder. Remove the metal hoses leading to the master cylinder, and save the hoses.
5. Pry open the retainer on the steering column. Remove the bolt at the base of the column connecting it with the steering box, using a 13mm. ratchet.
6. Remove the windshield wiper arms from the wiper knobs, and discard them. Unscrew the hardware from the wiper knobs, and save all hardware. Remove the windshield wiper motor assembly, and save it for use in the MiGi II.
7. Remove the two bolts beneath the gas tank area, attaching the body to the chassis, using a 17mm. ratchet.
8. Remove the front seats by releasing the catch at the end of the seat tracks. The seats will slide forward and off.
9. Remove the back seat by lifting up and out.

10. Unbolt the cables to the battery, and remove the battery. Save it, the rear bracket, and the positive lead and negative ground for use in the MiGi II.
11. Unbolt the voltage regulator at the driver side beneath the rear seat, and save it for use in the MiGi II.
12. Remove the four bolts attaching the body to the chassis from beneath the back seat, using a 13mm. ratchet. (Fig. 24.1)
13. Remove the two bolts at the base of the steering column where it meets the firewall. Cut the wires extending from the column, allowing as much of the wiring as possible to remain attached to the column.
14. Remove the bolts attaching the steering column bracket to the dash board, and save the bracket. Pull out the steering column with the wires, and save it for use in the MiGi II.
15. Disconnect the speedometer cable, by removing the clip on the driver side front wheel which extends through the axle cap.
16. Remove the rear wheels. In the rear fender well in front of each shock absorber, remove the bolt attaching the body to the chassis.
17. Disconnect the two generator wires, the oil warning light sender wire, and the coil wire.
18. Disconnect the throttle cable by loosening the linkage through the cable on the carburetor.
19. Disconnect the heater hoses from the heat exchangers, by loosening the clamp and sliding off the hose.
20. Place the chassis on a lift, or jack up one end at a time, to gain access to the body bolts on the underside of the chassis pan. Remove the 24 bolts from beneath the pan, using a 13mm. ratchet. Note: you may need to use a cutting torch to remove bolts which are badly rusted. (Fig. 24.1)
21. Remove the body from the chassis. The body can be lifted off using block and tackle, chain-hoist, or four to five strong people. If you are lifting the body off manually, be sure to lift it up over one side of the chassis, rather than over the front or rear of the car.

DISASSEMBLED V.W. CHASSIS (TOP VIEW OF CHASSIS) FIG. 24.1 AND 32.1

CONNECT MAIN BODY TO CHASSIS AT 24 POINTS

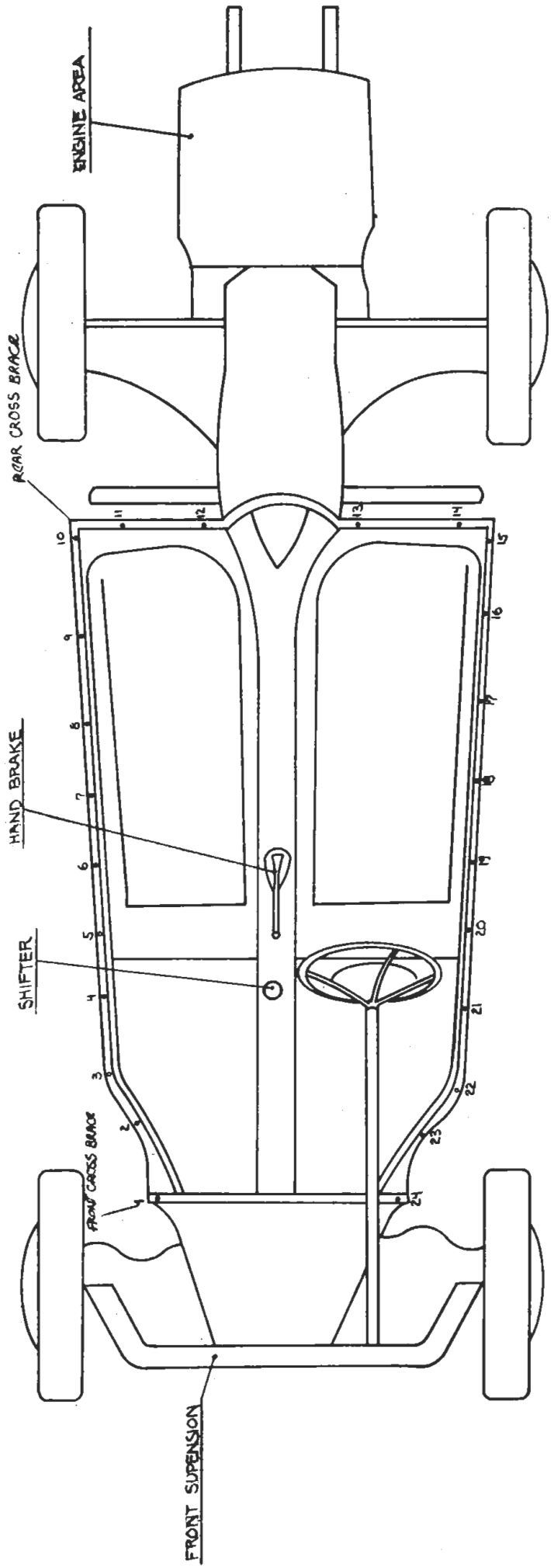

25 , INITIAL CHASSIS PREPARATION

After removing the body from the Volkswagen chassis, the chassis appears as it does in Fig. 25.1. Because of the accessability of chassis and engine components, this is a good time to do any chassis and engine repair work which may be required.

1. Replace shocks if excessively worn. Note: Do not use heavy-duty shocks. Lighter schocks are required because the MiGi II is much lighter in weight than the Volkswagen body.
2. Check the engine and transmission components, and repair or replace any components that are old or worn.
3. Replace any bad brake lonings, ect.
4. Repair any minor floorpan damage, using a fiberglass repair kit at any automotive supply store.
5. Chisel off the seat slides from the chassis pan (Fig. 25.1).
6. Chisel or cut the heater cable tubes from the chasis pan (Fig. 25.1).
7. Scrape the tar paper from the chasis pan.
8. To insure continued good condition of the chassis, steelbrush and coat the chassis with a rest-inhibitibe based paint.

VOLKSWAGON DISASSEMBLY & INITIAL CHASSIS PREP. FIG. 25.1

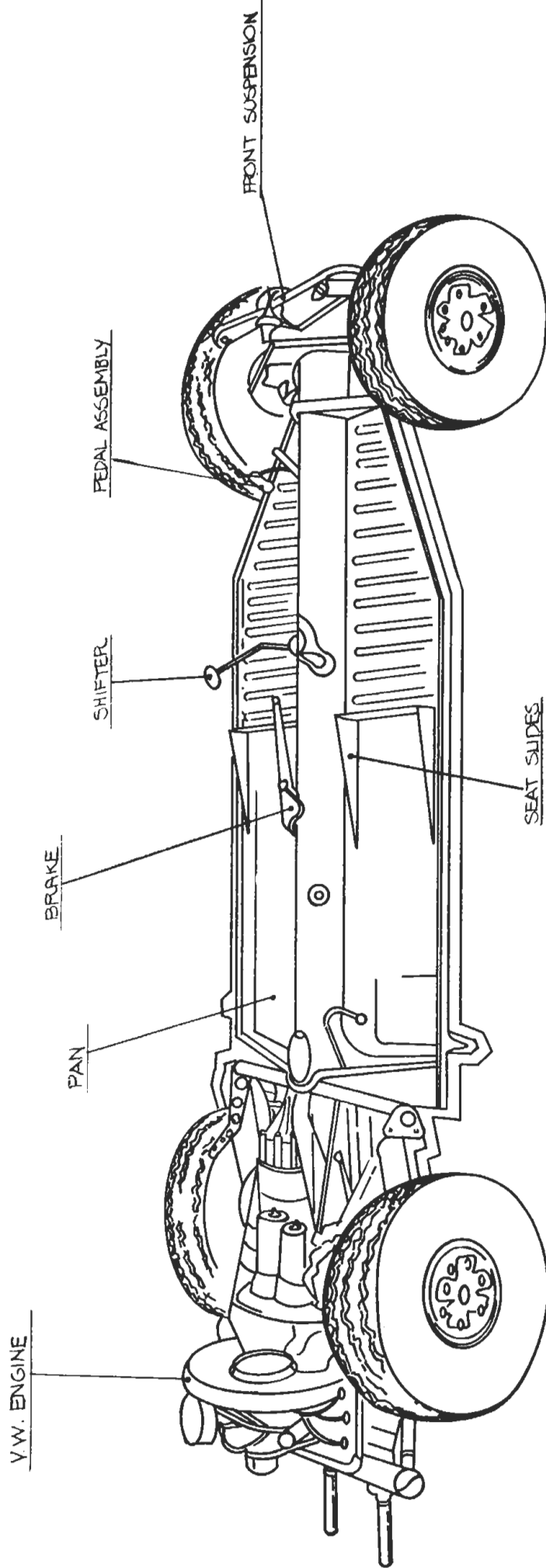

AFTER V.W. BODY HAS BEEN REMOVED

26. DECAMBERING REAR SUSPENSION

Tools and Materials Required:

Jack Stands
Wrenches

1. Place the rear wheels of the VW chassis on jack stands or blocks, and remove the rear wheels.
2. Unbolt the four bolts that hold the torsion bar dust cover cap, and the three bolts that hold the spring plate to the rear axle (Fig. 26.1).
3. Remove the dust cover and rubber bushing torsion bar and spring plate splined edges (Fig. 26.1).
4. Scribe a small line across the springplate and torsion bar splines to establish a reference point.
5. Once the reference point is established, pull the spring plate off of the torsion bar, being careful not to pull the inner torsion bar splines (in the center of the torsion tube) out. At the same time, disengage the spring plate from the rear axles. The rear axles will spring rearward out of the spring plate. Note: spring plates are under tension! when they disengage from the rear axle, keep hands clear.
6. Once the spring plate is disengaged, rotate the spring plate one notch counter clockwise on the driver side, and clockwise on the passenger side. The reference point marked above will indicate one notch moved.
7. Re-engage the spring plate at this point on the torsion bar and rear axle in the spring plate. Bolt the spring plate in place at the rear axle with the three bolts from the original assembly.
8. Replace the rubber bushing and bolt the dust cover cap into place, using the bolts from the original assembly.

9. The decambering is now complete. To check the suspension, have someone weighing between 160 and 185 pounds stand on the chassis, near the rear torsion bars. Roll the chassis back and forth. The rear wheels should be almost vertical.

DECAMBERING THE REAR SUSPENSION FIG. 26.1

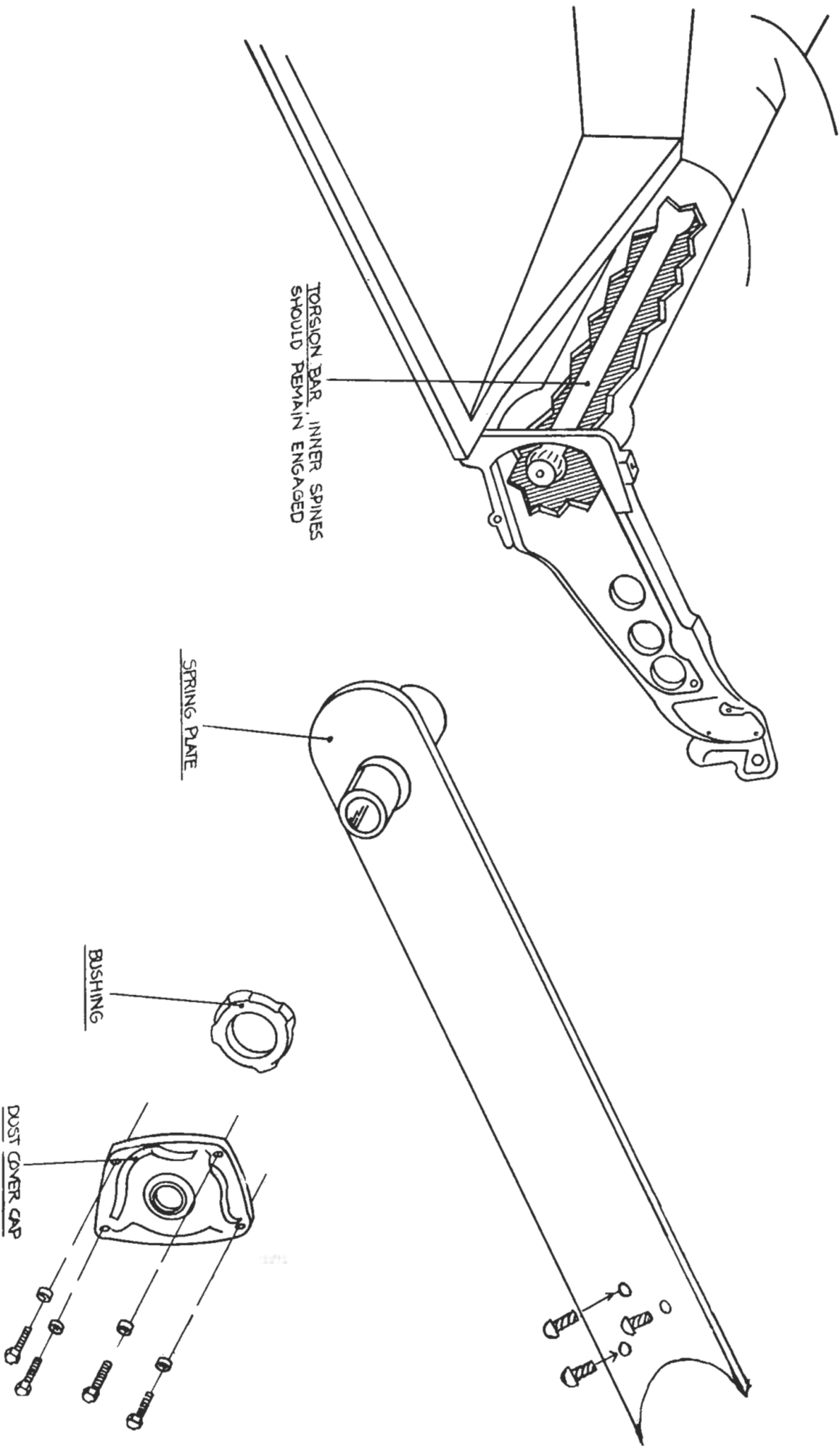

27. SOFTENING FRONT SUSPENSION

Because the MiGi II fiberglass body is lighter than the Volkswagen body, the front suspension must be modified or "softened," to compensate for the weight reduction.

Tools and Materials Required:

Wrenches
Screwdrivers
Scribe
Hack Saw
Welding Torch - Optional

1. Place the chassis front end on blocks.
2. Disconnect the brake lines on each side of the I-beam, by removing the holding clips and unscrewing the connecting lines.
3. Remove the steering damper on the front suspension
4. Disconnect the front suspension from the chassis, by removing the four bolts on the I-beams.
5. Scribe two lines around the lower torsion bar tube housing, 2" to the right and 2" to the left of the center bolt on the tube. (Fig. 27.1)
6. Using a hack saw or a pipe cutter, cut around the torsion bar tube housing, along the lines scribed in Step 5. Cut only through the tube housing: do not touch the torsion bars enclosed within the housing. When this procedure is complete, the 4" cut portion of the housing (with the center bolt) should move freely from the remainder of the housing, when weight is applied. (Fig. 27.1)
7. Before reinstalling the I-beam on the chassis, the shifter rod must be removed from the chassis. Complete Steps 1-5 of Operation 28, "Shifter Relocation."
8. Once the shifter rod has been removed, reinstall the I-beam on the chassis. Do not connect the brake lines and steering damper at this time.

9. Place approximately 175 lbs. of weight on the front of the I-beam. (A person standing on the I-beam will accomplish this). With the proper weight applied, the lower torsion bar should be 8" from the ground. (See Fig. 27.1)
10. Tack weld the center portion of the tube housing back to the sides of the tube housing in the same, weighted position obtained in Step 9. Note: All welding can be done when the car is totally assembled. The car can be driven to a gas station for welding.
11. Remove the I-beam from the chassis and permanently weld the center of the torsion bar tube housing to the side housing.
12. Reinstall the I-beam onto the chassis. Reconnect the brake lines and steering damper, using the original clips, etc.

LOWERING (SOFTENING) THE FRONT SUSPENSION - FRONT END ASSEMBLY FIG. 27.1

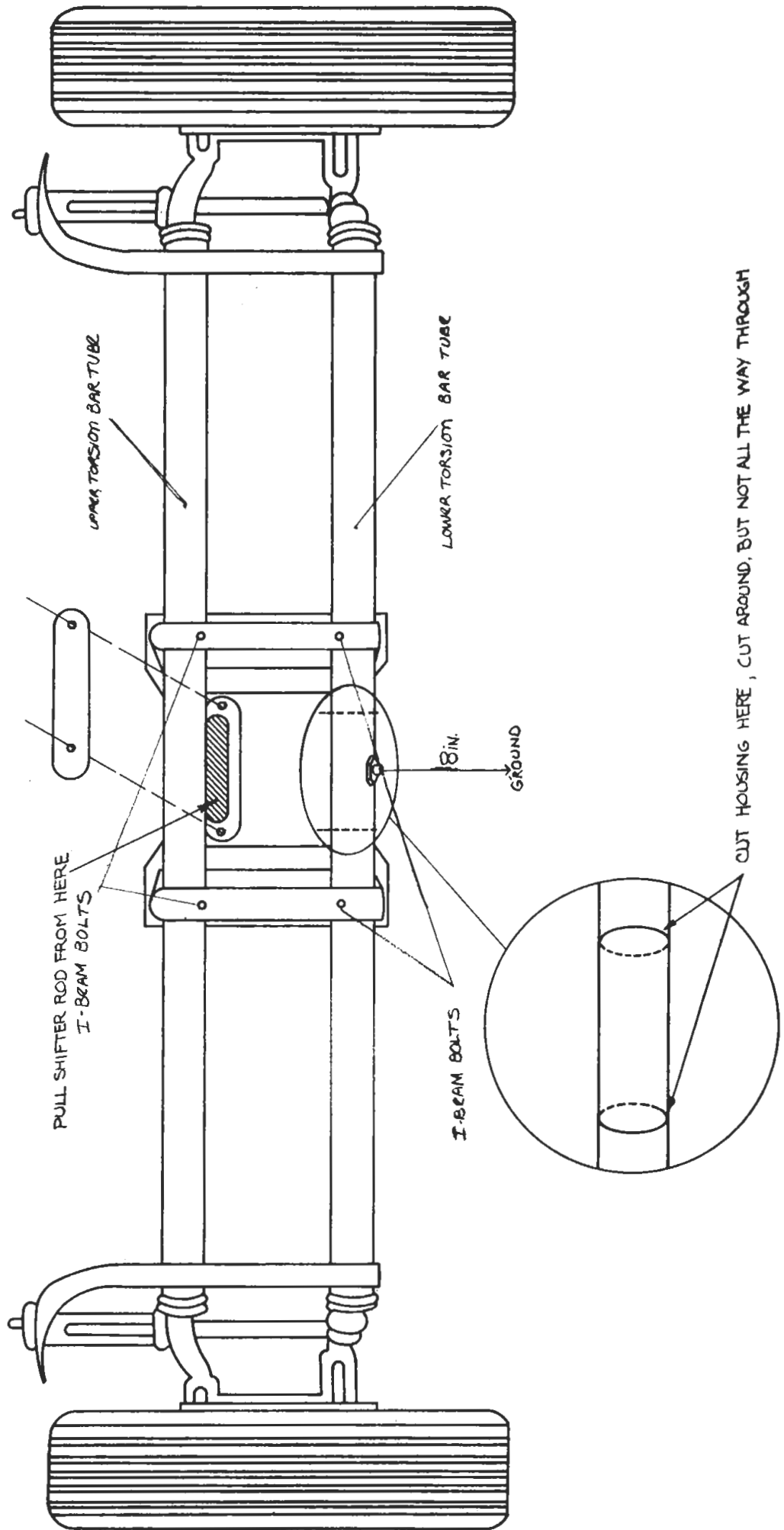

28. SHIFTER RELOCATION

Before beginning the relocation of the shifter, the I-beam must be removed from the chassis, as in Operation 27, "Softening the Front Suspension." Complete Steps 1-5 of the Shifter Relocation before reattaching the I-beam to the chassis.

Fiberfab Parts Required:

MX 192 Shifter Relocation Kit

Tools and Materials Required:

Electric Drill
Drill Bit: 3/8"
Hack Saw
Wrenches
File
Scribe
Screwdriver

1. Remove the two bolts attaching the shifter plate to the center channel. Pull out the shift lever, the shifter plate and the spring from the channel, noting their relative positioning for future reinstallation. (Fig. 28.1)
2. Remove the access plate cover plate over the rear shift coupler. (Fig. 28.1)
3. Disconnect the shifter rod at the rear shift coupler (located under the access cover plate) by removing the center bolt. Save the bolts, washers, etc. from the shift coupler assembly.
4. Remove the access plate to the center channel, located at the front of the chassis, by removing the 2 bolts.
5. Force the shifter rod through the center channel toward the front of the chassis, working it all the way through the tunnel. Pull the shifter rod out through the front of the center channel (where access plate was removed, Step 4). Replace the access plate at the front of the channel wall, using the original bolts.
6. Scribe a point on the top of the center channel wall 4" behind the rear edge of the hand brake.
7. Measure the distance from the point scribed in Step 6 to the center of the original

shifter location hole. Note this measurement for use in a later step.

1'9½"

8. Using a 2" hole saw, drill a hole in the top of the center channel wall, at the point scribed in Step 6. Note: Be careful to drill only through the channel wall without touching the cable tubes located within the channel. These cable tubes will be visible when the 2" hole is complete.
9. Carefully push the cable tubes inside the channel out toward the channel wall, to allow for the passage of the shifter rod. A 1" x 1" x 10" piece of wood works well as a "prying" instrument to accomplish this. (Fig. 27.1)
10. Position the shifter relocation plate (supplied with the kit) over the 2" hole drilled in Step 8. Using the plate as a template, scribe the front and rear mounting holes onto the top of the center channel wall. Drill out the mounting holes, using a 5/16" drill bit. (Fig. 28.1)
11. Place the shifter rod on its side on a flat surface. Scribe a line on the shifter rod which will be the same distance from the shift rod coupler pin hole (located at the back end of the shift rod) as the measurement obtained in Step 7. (Fig. 28.2, #1)
12. Scribe a line along the length of the shifter rod, to intersect the line scribed in Step 11. The line should project from the center of the shifter socket to the center of the shift rod coupler pin hole. (Fig. 28.2) The intersection of this scribe line and the line scribed in Step 11 marks the center of the new shift rod coupler pin hole.
13. Drill a 3/8" hole all the way through the shifter rod, at the intersection point located in Step 13 (Fig 28.2). Note: The hole can be most easily and accurately drilled by using a center punch first, at the point of drilling.

14. Scribe a line around the shifter rod 1/4" behind the new shift rod coupler pin hole. Cut the shift rod at that line using a hack saw (Fig. 28.2, #2).
15. Insert the teflon bushing into the shifter relocation plate (both supplied with the kit). Slide the relocation plate with bushing onto the shifter rod, as shown in Fig. 28.2, #3.
16. With the shifter rod on its side, slightly flatten the sides of the rod at the point of the shift rod coupler pin hole. This will facilitate reinstallation of the shifter rod into the rear shift coupler (Fig. 28.2, #4).
17. Replace the shifter rod in the center channel, through the rear shift access hole (Fig. 28.3). The handbrake and clutch cable tubes will act as a "track," facilitating the positioning of the shifter rod inside the channel.
18. Reinstall the shifter rod in the shift coupler (through the new shift rod coupler pin hole), using the original nuts, bolts, etc. (Fig 28.2 #4, Fig. 28.3)
19. Reinstall the shift lever assembly (over the shift socket in the shift rod) on the top of the center channel wall. Include the shifter plate and spring. Use the original bolts, which will screw into the shifter relocation plate installed on the shift rod, inside the tunnel. Fig. 28.1. Fig. 28.3.
20. Replace the access plate cover over the rear shift coupler, using the original bolts.

RELOCATING THE SHIFTER AND PEDAL ASSEMBLY FIG. 281

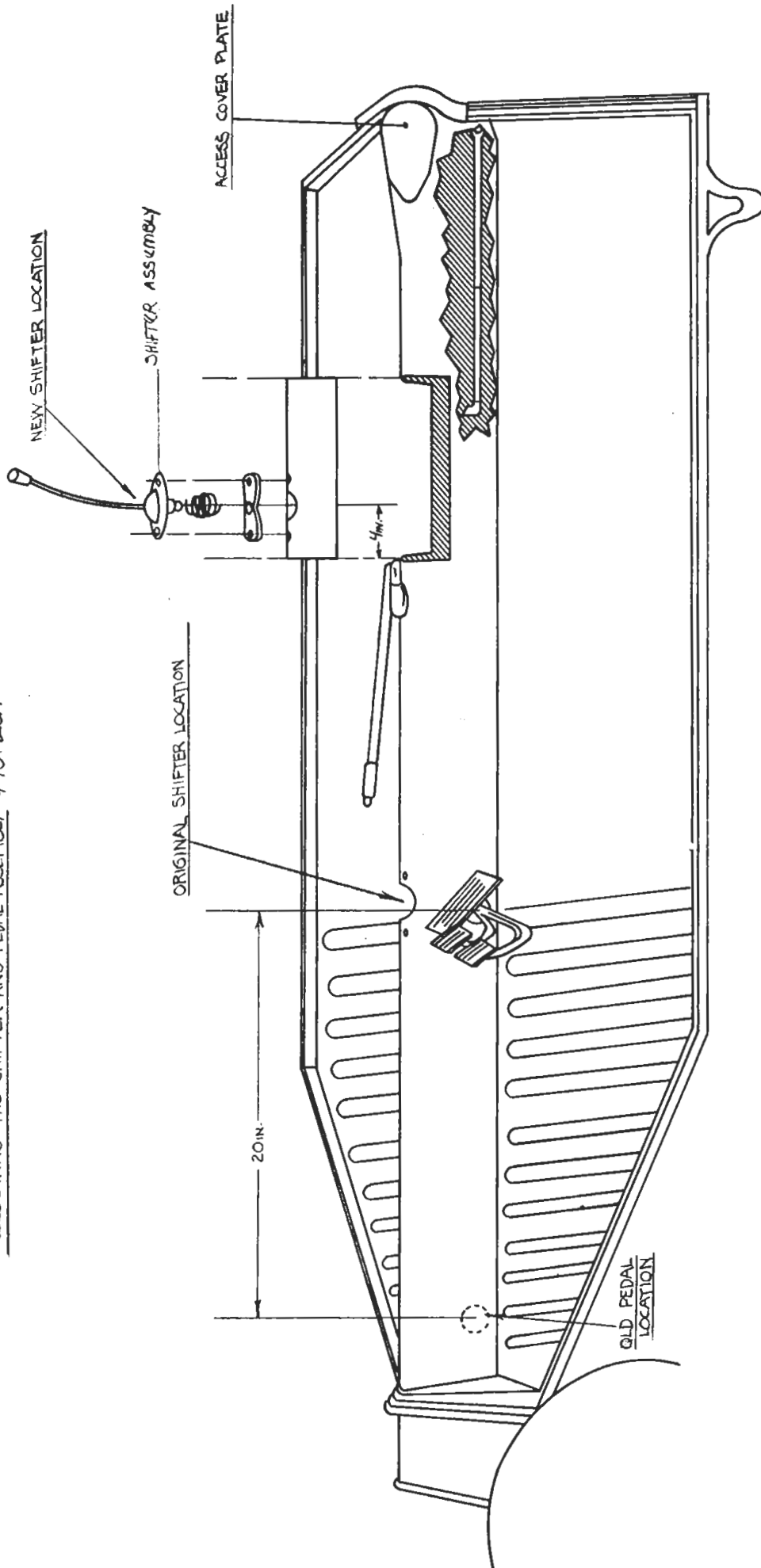

SHORTENING THE SHIFTER ROD

SCRIBE LINE FOR PERFECT REALIGNMENT

FULL LENGTH ROD

SHORTENED ROD

NEW HOLE

SHIFTER COUPLER PIN HOLE

NO WELD SHIFT ROD SHORTENING

1 MEASURE, CENTERPUNCH AND DRILL $\frac{3}{8}$ " HOLE

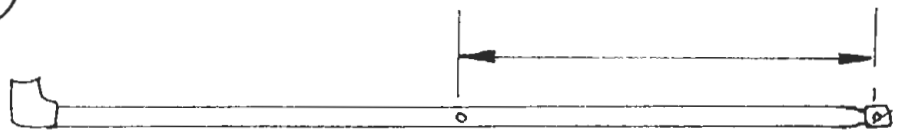

2 CUT ROD $\frac{1}{4}$ " BEHIND HOLE



3 SLIDE SHIFTER RELOCATION PLATE (WITH TEFLON BUSHING INSTALLED) ONTO THE SHIFT ROD



4 ROD IS ROTATED $\frac{1}{4}$ " TURN FLATTEN ROD SLIGHTLY TO MATE WITH TRANS-AXLE SHIFT COUPLER

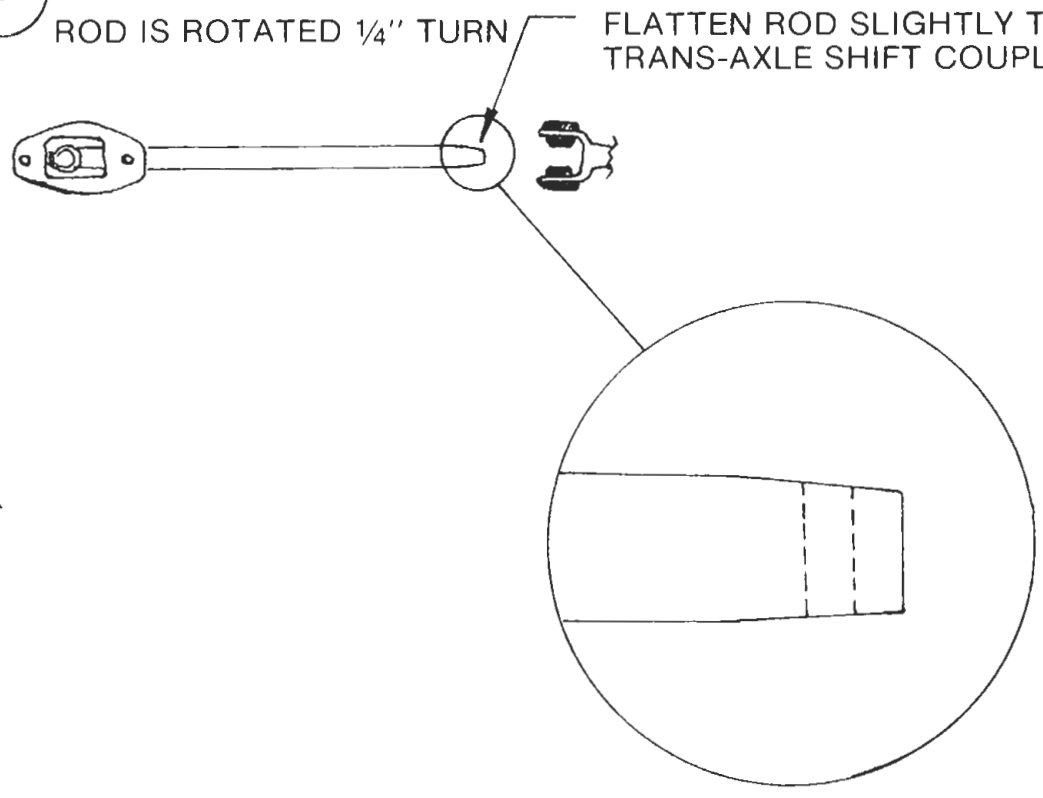

"NO WELD SHIFT RELOCATION Kit"

SHIFTER ROD

SHIFTER Kit MX-192



"How to INSERT 'ROD'"

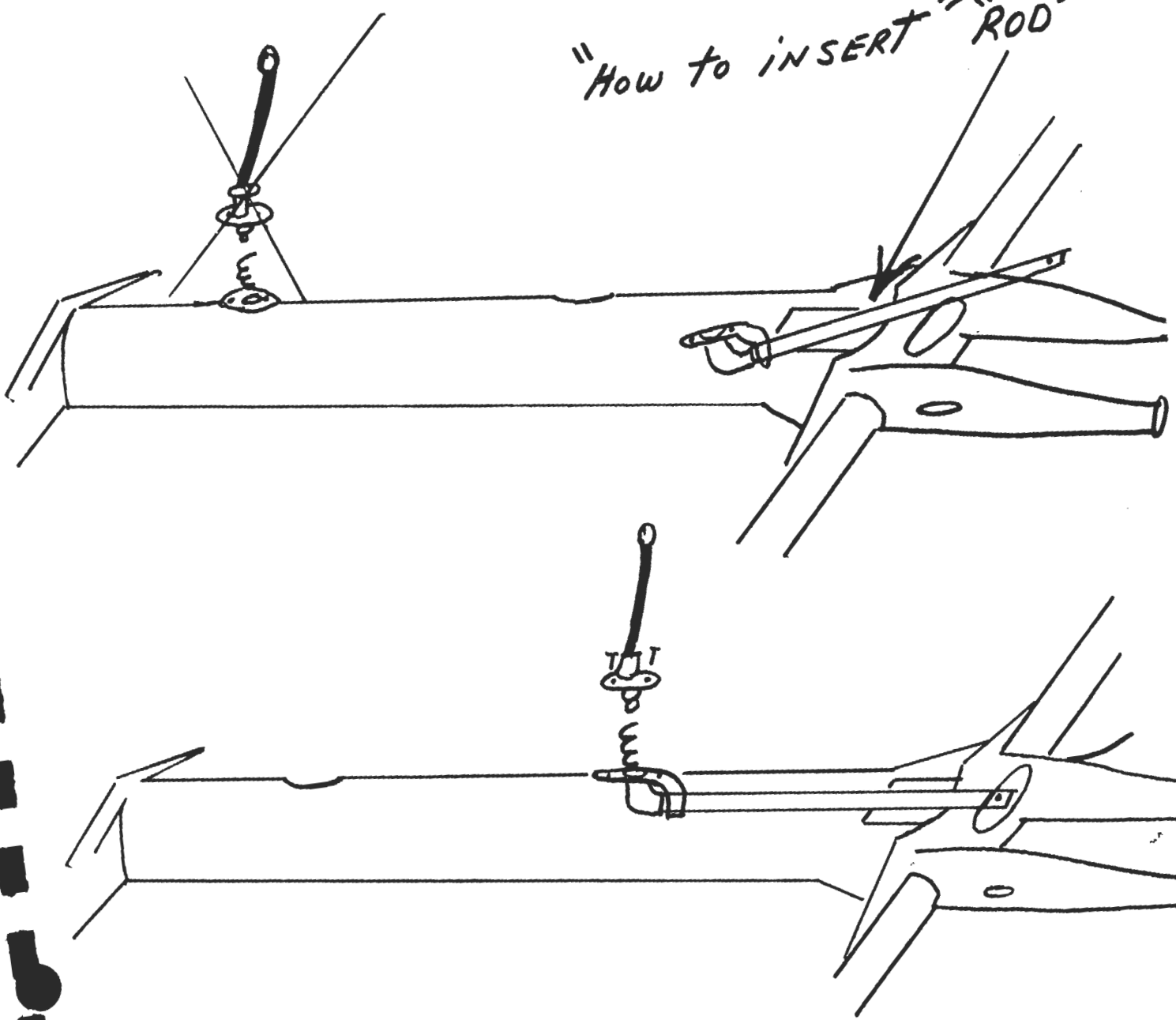

29. PEDAL RELOCATION

Fiberfab is in the process of developing a new pedal relocation kit, which will be included with the MiGi II beginning May 1, 1979. The new pedal relocation kit will be attached to the original pedals, eliminating all cable shortening, alterations to the tunnel wall, brake extension, etc. MiGi II owners who purchased their kit prior to May 1 can order the pedal relocation kit directly from our Manufacturing Plant in Milpitas, California.

The following instructions for relocating the pedals utilize the original pedal assembly from the Volkswagen chassis.

Fiberfab Parts Required:

M555 Bolt Kit

Tools and Materials Required:

Wrench
Screwdriver
Scribe
Hole Saw: 2"
Electric Drill
Drill Bit: 5/16"
Hammer
1/8" metal tubing
Hack Saw
File

1. Remove the two bolts attaching the pedal assembly to the tunnel wall (Fig. 29.1).
2. Disconnect the throttle cable from the carburetor and the clutch cable from the eyelet on the transaxle. Pull the pedal cluster out from the tunnel wall, including the cables, and save all parts including the cables.
3. Scribe a line on the driver side wall of the center tunnel 20" behind the center of the original pedal location hole. Note: 20" is an approximate measurement, and should be adjusted according to the driver's height: A person 5'8" to 5'10" will be comfortable using the 20" measurement. A taller person should mark a point at 18" to 19". A shorter person should mark a point at 21" to 22".
4. At the line scribed in Step 3, use a 2" hole saw to drill a hole in the tunnel wall so that the bottom edge of the hole will be tangent with the floorpan, as the original pedal hole was.

5. Using a heavy hammer, pound the tunnel wall in front of the 2" hole to form a slight indentation. This will allow for free movement of the gas pedal.
6. Scribe a line 4" behind the center of the 2" hole in the tunnel wall. Cut through the tunnel wall, 2½" vertically at this scribe line, as shown in Fig. 29.1. Note: you may have to make several drill holes in a vertical line and use a hack saw to connect them into a straight cut. In cutting the tunnel wall, you will also cut through the cable tubes within the tunnel.
7. Using a heavy hammer, pound in the tunnel wall lightly at the front of the 2½" vertical cut. This will open the cut and provide access to the cable tubes inside the tunnel. File smooth the edges of the cut in the tunnel wall.
8. Cut a piece of 1/8" metal tubing 1½" long. Grind or file one end so that the end will fit inside the throttle cable tube. The fabricated tube end will act as an extension of the cable tube inside the tunnel, so that the throttle cable can pass easily from the tunnel to the pedal cluster without bending or fraying.
9. Remove the throttle cable from the pedal cluster. Slide the fabricated tip over the cable, and insert the cable through the cable tube inside the tunnel at the point of the 2 1/2" vertical cut. The cable should extend to the engine, and the fabricated tip should fit into the end of cable tube in the tunnel wall and protrude through the vertical cut to the outside of the tunnel wall (Fig. 29.1).
10. Position the pedal assembly in the new 2" hole and scribe the mounting holes at each side onto the tunnel wall. Drill the mounting holes using a 5/16" drill bit.
11. Remove the pedal stop from the floor pan and save the bolt. Hold the pedal assembly in place with the brake and clutch pedals in a vertical position.

Place the pedal stop in front of the two pedals, against the slight indentation at the base of each pedal. Scribe the center bolt hole of the stop onto the floor pan, and drill using a 5/16" drill bit. Bolt the stop to the pan, using the original bolt on a 3/16" x 1/2" hex head bolt.

12. Insert the clutch cable through the cable tube at the new 2" pedal hole location, and hook the cable end onto the pedal assembly (Fig. 29.1). At the rear of the car use a vice grip to hold the cable taut, preventing it from slipping off of the pedal assembly.
13. Attach the throttle cable to the accelerator linkage behind the gas pedal. Cable connections to the engine will be made at a later step.
14. Bolt the pedal assembly to the tunnel wall using the original mounting bolts.
Note: In order to gain access to the inside of the tunnel for securing the nuts and washers, you may have to drill a 2" access hole on the opposite tunnel wall directly across from the pedal assembly. After attaching the pedal assembly, replace the tunnel wall cut over the hole and secure with a fiberglass matting kit.

REMountING PEDALS FIG. 29.1

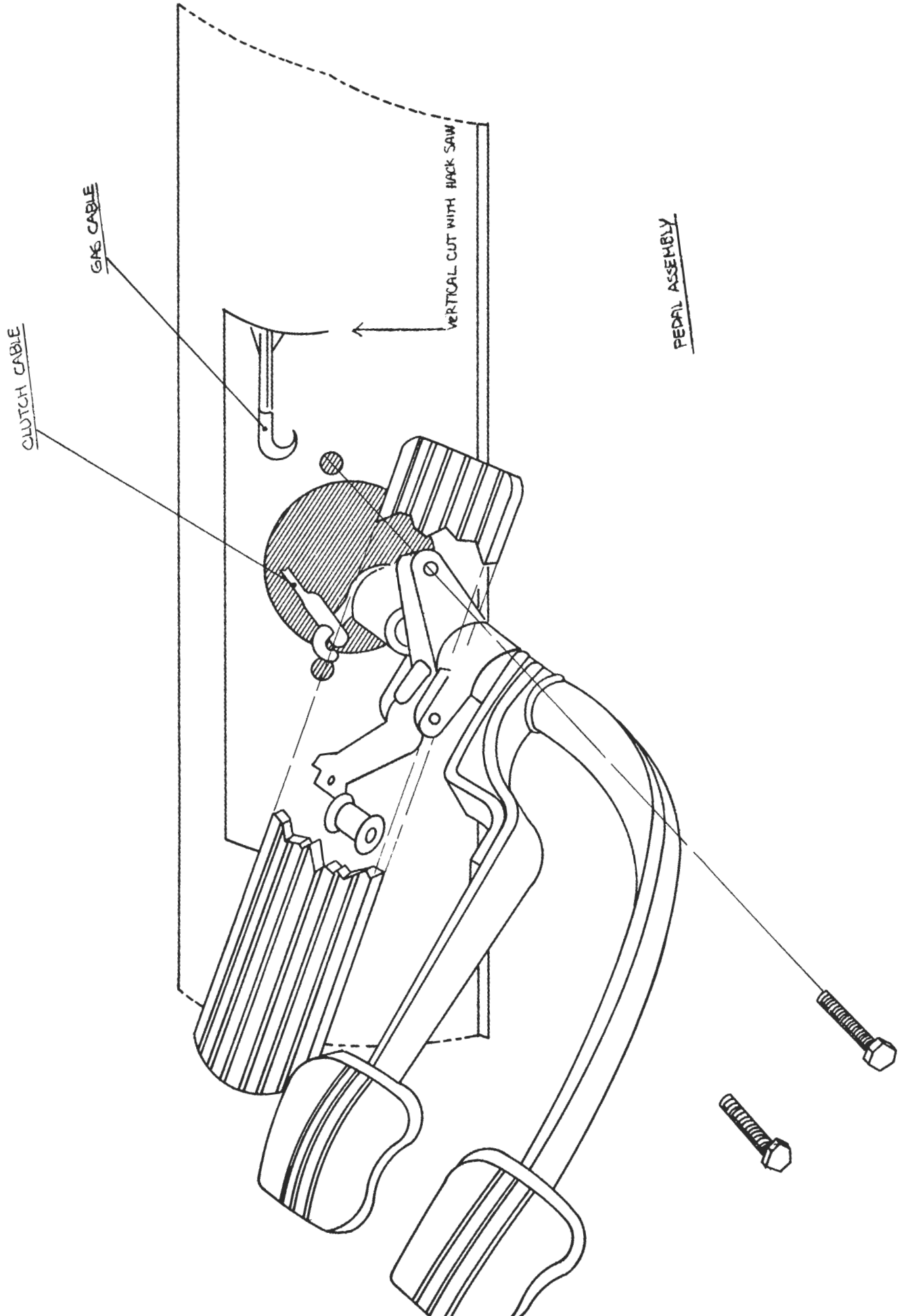

30 BRAKE EXTENSION

Fiberfab Parts Required:

x128 Brake Extension

1. Remove the master cylinder push rod from the brake pedal, by releasing the C-clamp and spring from the pedal.
2. To fabricate the end for the new master cylinder push rod, grind the head off of a 3/8" x 3 1/2" bolt. The bolt, when properly finished, should fit into the master cylinder where the original master cylinder push rod was (Fig. 30.1).
3. Thread two 3/8" nuts onto the 3/8" bolt. Force the threaded section of the bolt into the brake rod extension (supplied with the kit) as in Fig. 30.1).
4. Place the fabricated end into the master cylinder, and insert the end of the original master cylinder-push rod into the open end of the brake rod extension.
5. Reconnect the original master cylinder push rod (with brake extension and fabricated end) to the brake pedal. Adjust the double nuts on the 3/8" bolt so that there is no play in the components of the brake extension.

EXTENDING THE BRAKE ROD FIG. 30.1

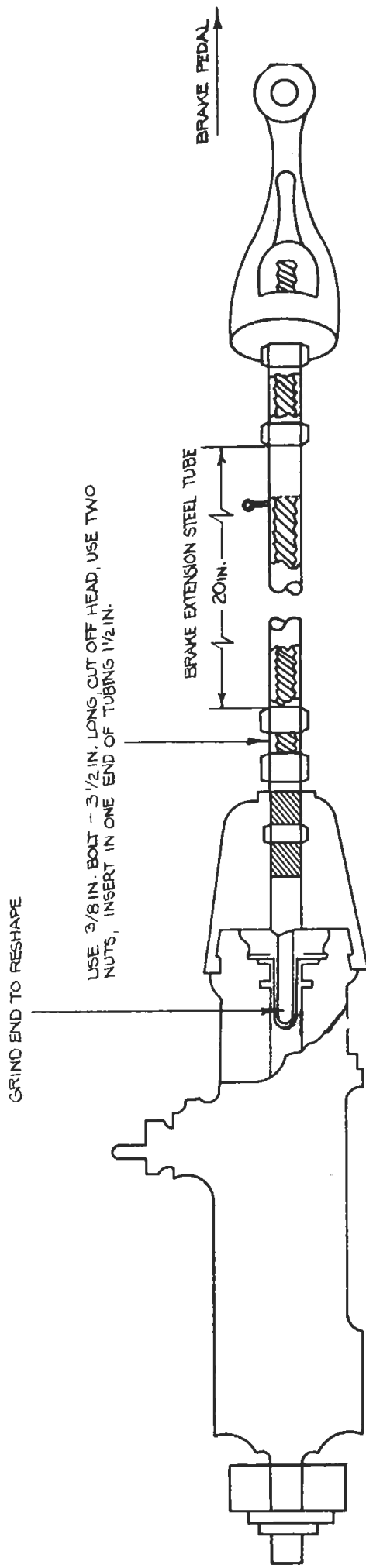

31. REAR SUPPORT BRACKETS

Fiberfab Parts Required:

M511 Rear Support Brackets
M516 "L" Brackets

Tools and Materials Required:

Wrench

1. Mount the rear support brackets onto the rear shock towers, at the same two resting points used to support the original VW body. The brackets should be mounted so that the rear bumper support flanges turn to the inside of the car (Fig. 31.1). Use the original bolts from the VW pan for mounting.
2. Use the "L" brackets (supplied with the kit) to mount the support brackets on the upper step of the shock towers. Note: the "L" bracket will have to be shimmed with 5 to 6 washers at a later step, when the body is mounted, so that the rear splash panel meets the engine cover properly.

REAR BODY SUPPORT HANGERS FIG. 31/ AND 34/1

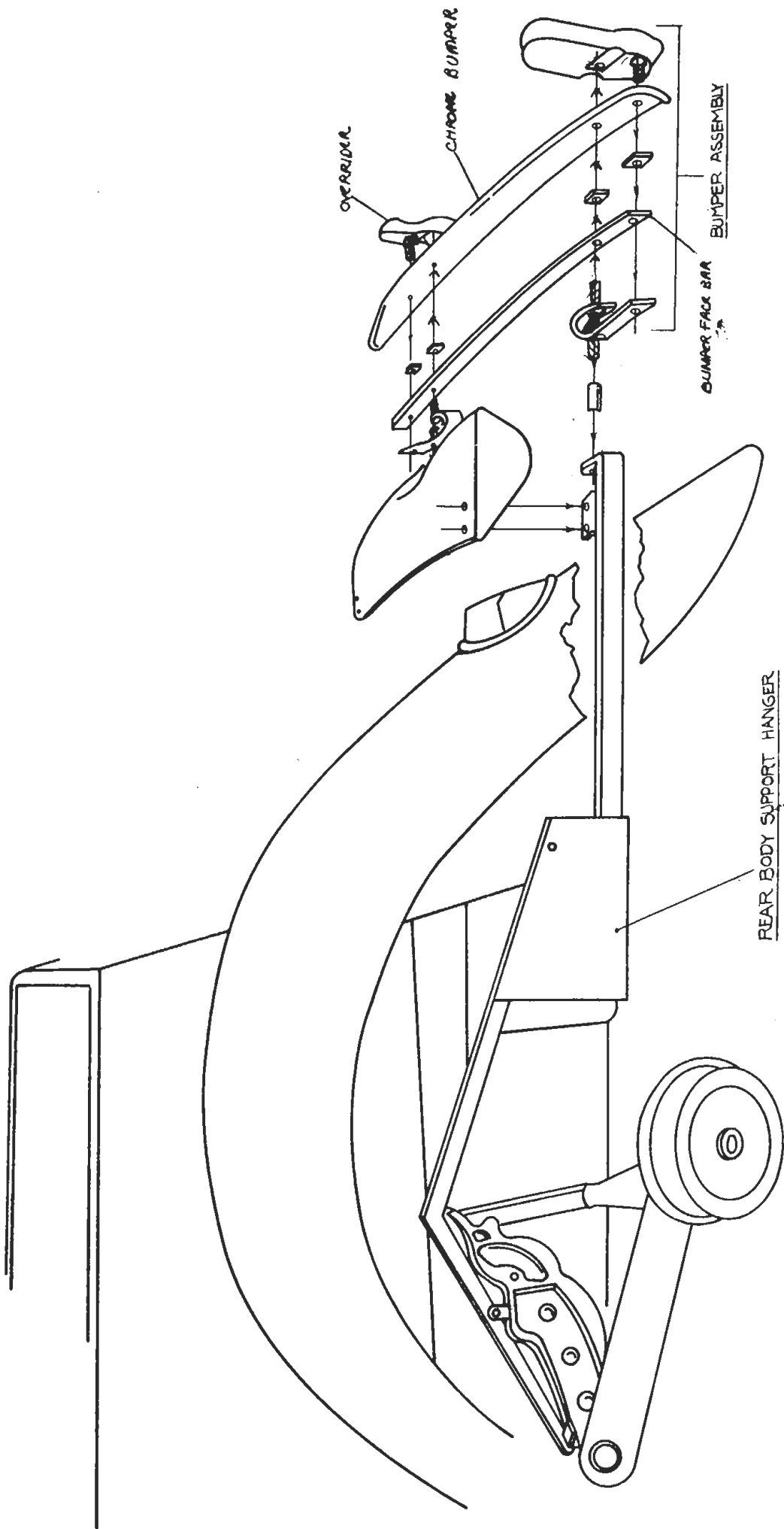

32. MOUNTING THE MlGl II BODY ON THE VW PAN

Fiberfab Parts Required:

X130 Floor Pan Gasket
M555 Bolt Kit

Tools and Materials Required:

Electric Drill
Drill Bit: 5/16"
Wrench
Rubber Cement

1. Place the new pan gasket onto the VW chassis mounting flanges.
Note: The gasket will be most air tight if it is glued into place with rubber cement or a similar strong adhesive.
2. Drill holes through the gasket at the points where the bolt holes is the mounting flanges are beneath the gasket. The bolt holes points can be located by running the tip of a drill bit along the gasket. The rubber will "give" at the points of the bolt holes.
3. Using 3 to 4 people. lift the MiGi body onto the VW chassis. Move the body back on the chassis, until the front mounting flange on the main body section rests flush against the front cross member of the VW chassis. The main body side flanges should overlap the mounting flanges on the sides of the VW chassis. Note: There may be a slight gap (1" - 1½") between the rear main body flange and the rear cross bracing above the shift coupler access hole. When the body is fastened down, this gap should be eliminated and can be sealed with silicone sealer or a body filler.
4. When the body is positioned correctly, drill up through the VW pan mounting holes through the main body section flanges (Fig. 32.1). Note: From the running boards to the front of the main body, the mounting flanges are toward the outside of the body section. From the running boards to the rear of the main body, the mounting flanges are toward the inside of the body section, beneath the doors and across the rear edge.

5. Secure the main body to the VW chassis, using 5/16"-18 x 1½" step bolts, nuts and washers.
6. Drill through the plate on the rear support brackets, through the inner flange at the base of the rear fender, and through the flange at the bottom side of the main body, using a 5/16" drill bit. Bolt the support bracker, fender flange and main body flange together, using ¼-20 x 1½" bolts and nuts.

DISASSEMBLED V.W. CHASSIS (TOP VIEW OF CHASSIS) FIG. 24.1 AND 32.1

CONNECT MAIN BODY TO CHASSIS AT 24 POINTS

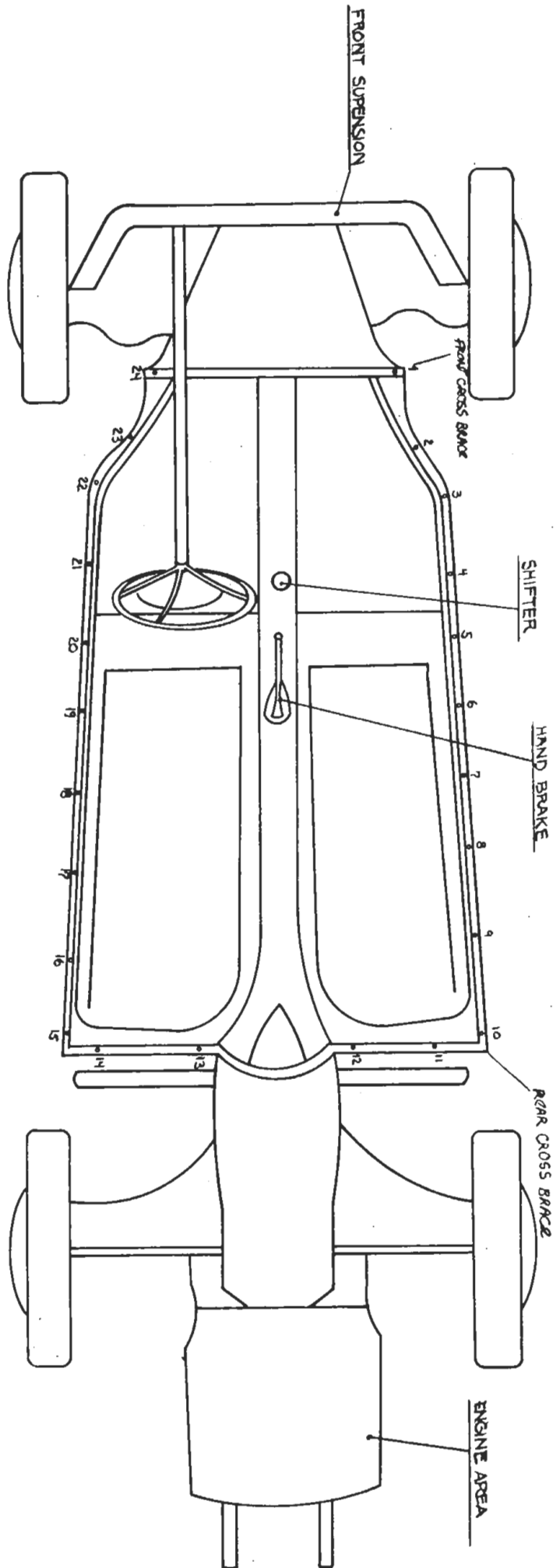

33. ATTACHING THE STEERING COLUMN

The 1961 through 1967 steering column is recommended for use in the MiGi II, both for ease of installation and for safety. These steering columns can be purchased at most salvage yards. A 1968 or newer column can be used; however the column lock collar must be adapted to fit the dash.

Fiberfab Parts Required:

M562 Steering Extension
MX199 Steering Bearing

Tools and Materials Required:

Wrench
Screwdriver
Electric Drill
Drill Bits: $\frac{1}{2}$ ", $\frac{1}{4}$ "
Hole Saw: 2"
Hammer

1. Remove the steering wheel from the steering column. Remove the VW steering wheel by unscrewing the center nut underneath the horn buttons. Rethread the nut over the top of the center bolt. Holding the steering wheel, use a hammer to pound over the nut until the bolt pulls away from the wheel. The nut over the top of the bolt will protect the threads while pounding. Note: This operation required two people: one person holding the steering wheel and one person pounding the nut and bolt away from the wheel. Save the nuts, washers, etc.
2. Install the steering column bearing onto the lower end of the steering column shaft (Fig. 33.1). The bearing will help to stabilize the lengthened shaft.
3. Install the rubber grommet (from the original VW steering assembly) around the column tube.
4. Remove the splined shaft coupler from the rubber disc on the steering box. Using the original clamp, bolt the coupler to the steering shaft (Fig. 33.1).
5. Bolt the steering column extension to the splined shaft coupler (Fig. 33.1).
6. Project a line from the steering box on the I-beam (underneath the grill shell) through the hole in the driver hood side, and the hole in the front of the main body, to a point on the fire wall. Scribe this point and drill using a $\frac{1}{2}$ " drill bit.

Continue to project the line through the firewall hole to the recess in the dash board. When the 1/2" hole is properly positioned, the projected line should extend to 7/8" below the recessed edge (the center point of the steering column). Adjust the position of the 1/2" hole as necessary and then drill using a 2" hole saw. Note: In projecting the line to obtain the firewall hole, a thin metal rod leg, a radio antenna or metal tape measure can be used to establish the line.

7. Insert the extended steering column through the holes in the firewall, main body bulkhead, and hood side (Fig. 33.2).
8. Bolt the steering extension end to the rubber disc on the steering box (as the original splined shaft coupler was attached) using the original bolts (Fig. 33.2).
9. Bolt the steering column into place in the recessed area of the dash board, using the original steering column support bracket and bolts (Fig. 33.2).
10. Push the rubber grommet around the steering column tube into the hole in the firewall.
11. Place the new steering wheel and adaptor over the steering column, according to the instructions included with the adaptor.

STEERING COLUMN FIG. 33.1

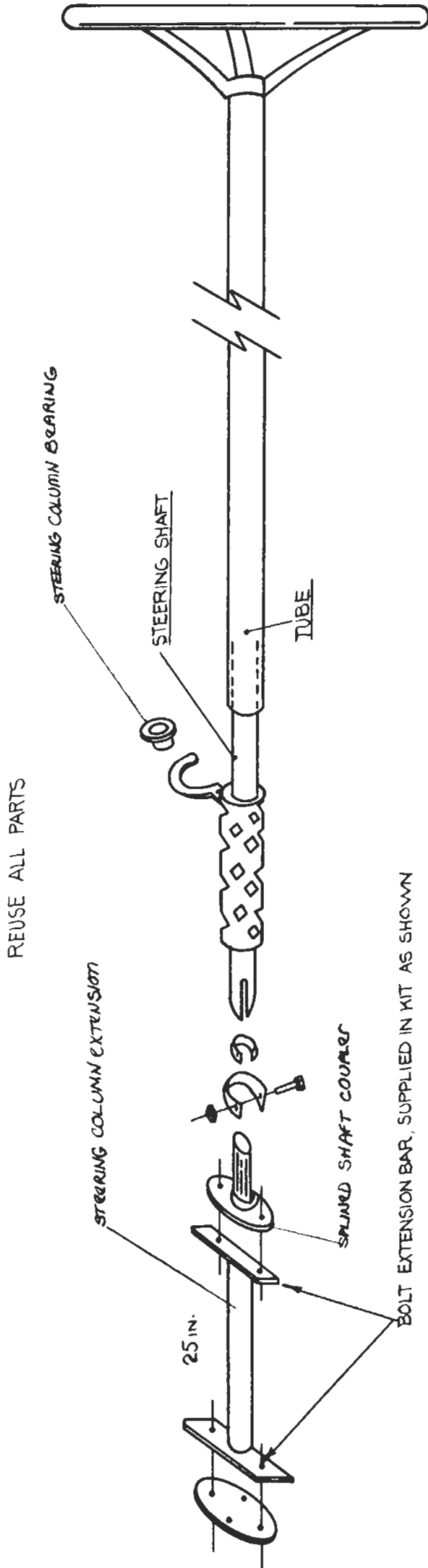

STEERING COLUMN - EXTENDING COLUMN FIG. 33,2

CUT OUT AREA SCRIBED
ON LOWERED SIDE PANEL,
DRIVERS SIDE

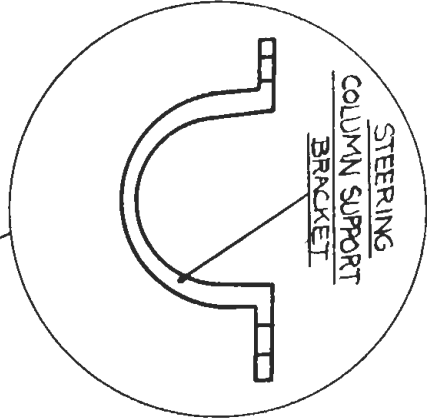
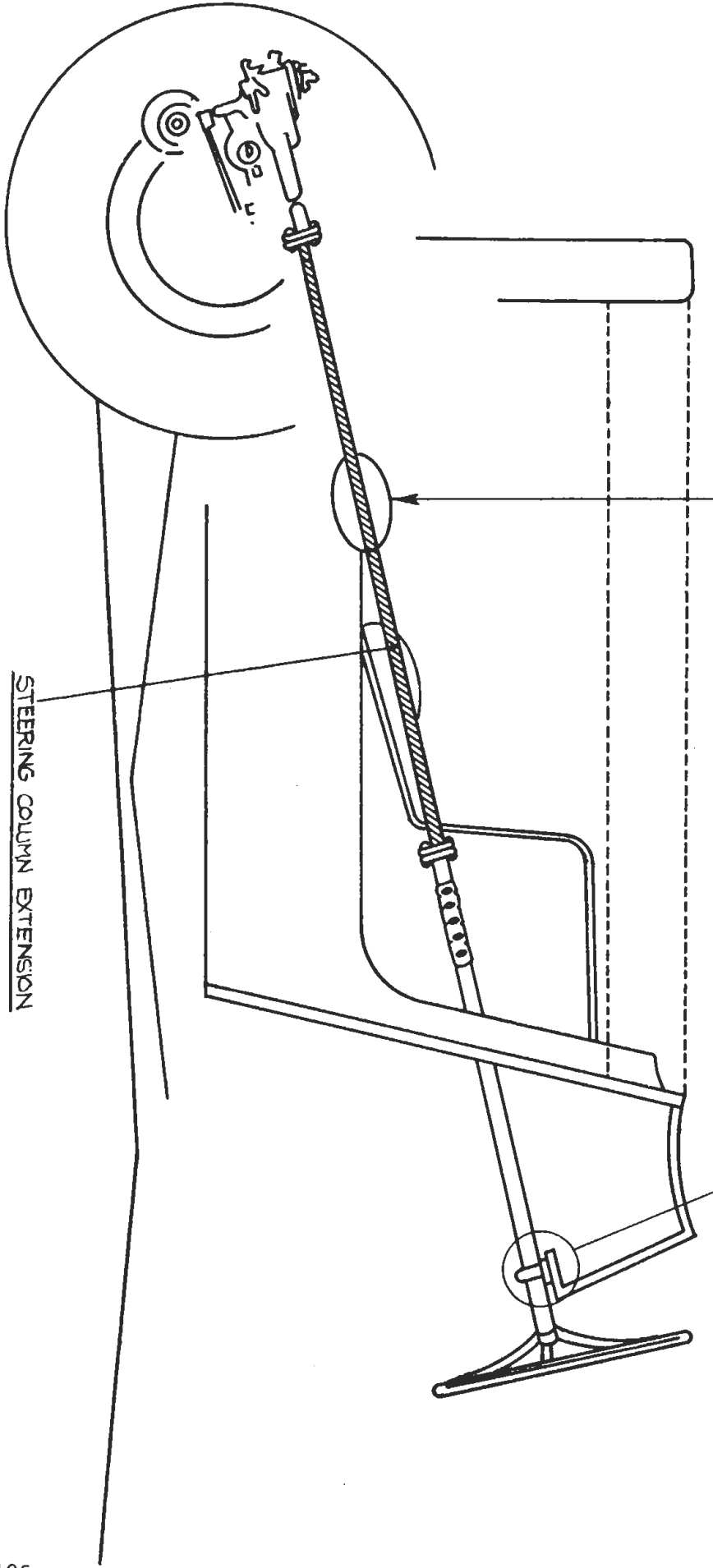

STEERING COLUMN EXTENSION

34. REAR SPLASH PANEL AND REAR BUMPERS

Fiberfab Parts Required:

M523 Bumper Assembly
M555 Bolt Kit

Tools and Materials Required:

Scribe
Electric Drill
Drill Bits: 1/4", 3/8"
Wrench

1. Place the rear splash panel over the rear support brackets, as illustrated in Fig. 34.1. Scribe through the mounting holes in the support bracket flanges onto the underneath side of the splash panel (Fig. 34.1).
2. Remove the splash panel from the support brackets. Drill out the mounting holes scribed in Step 1, using a 1/4" drill bit.
3. Drill out the prescribed holes at the back of the splash panel, where the rear bumper mounts. Use a 3/8" drill bit.
4. Secure the rear splash panel to the rear support brackets, using 1/4-20 x 1 1/2" phillips bolts and nuts.
5. The top edge of the rear splash panel should be approximately 12" from ground level, so that the engine cover rests against it. If necessary, adjust the height of the splash panel by shimming the rear support brackets upward from the "L" brackets. Place several washers between the "L" bracket and the support bracket, until the splash panel reaches the correct height. (Fig. 34.1)
6. Position the rear bumper face bar against the inside of the rear bumper, placing square spacers between the bumper and the face bar at bolt holes. Place the small S-brackets over the face bar, and bolt the S-brackets, face bar and bumper together at each end. Use the chrome headed bolts included with the bumper assembly (Fig. 34.1).
7. Position the overriders against the outside of the rear bumper at the two inner side bolt holes. Bolt together the inside of the S-bracket, the face bar, the bumper and the overriders using 3/8" fine thread bolts. The bolts thread directly into the overriders (Fig. 34.1).
8. Position the rear bumper (with brackets and overriders) against the rear splash panel, aligning the bolt holes. Place the large metal cylinder spacers between the S-bracket and the splash panel. Bolt the S-bracket, spacers, splash panel and rear support bracket flanges using 3/8"-18 x 3" bolts.

REAR BODY SUPPORT HANGERS FIG. 3.1/2WD 34.1

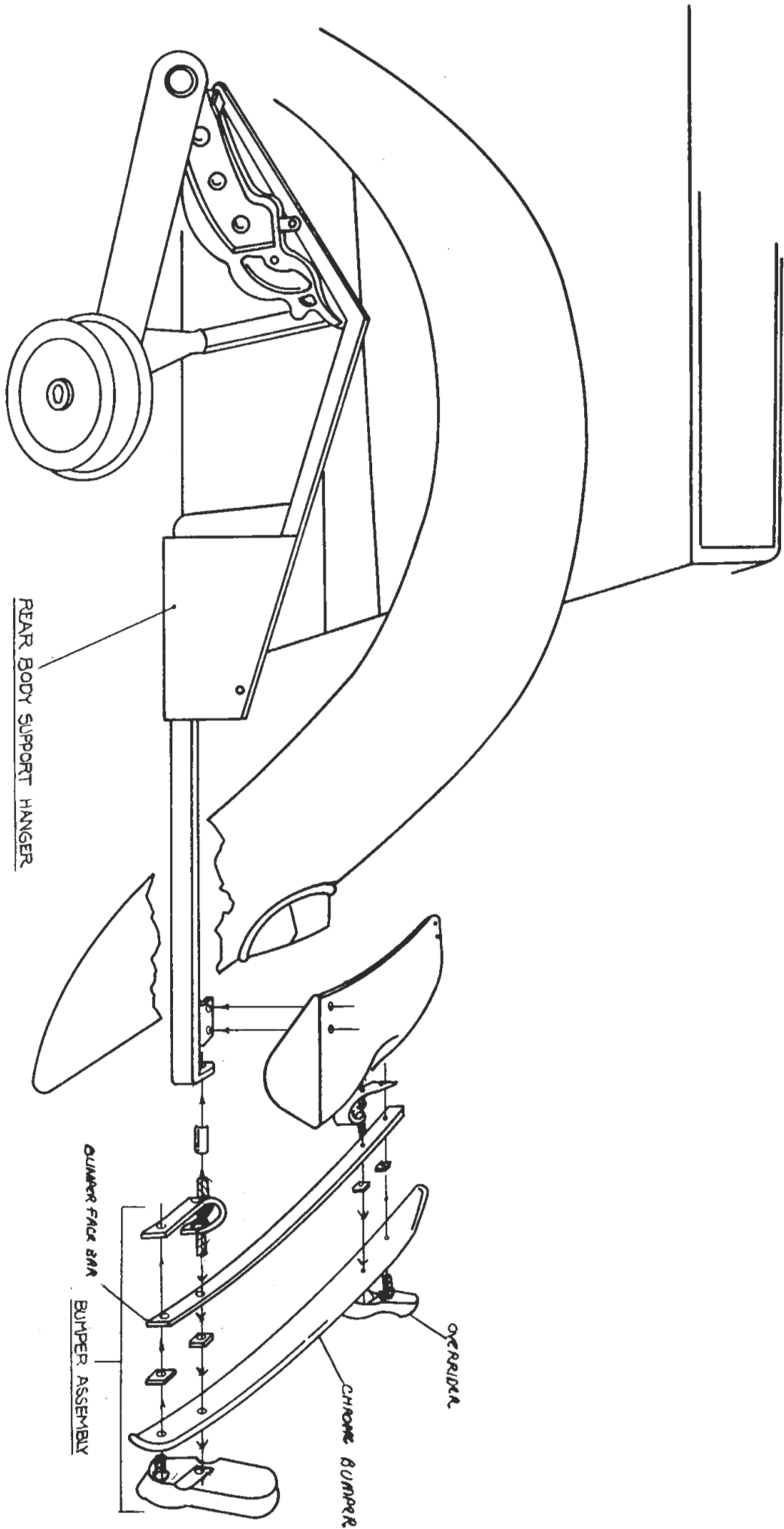

35. ENGINE COVER HOLDDOWNS AND BACK-UP LIGHT

Fiberfab Parts Required:

M529 Back-up Light
M530 Engine Cover Holddowns
M555 Bolt Kit

Tools and Materials Required:

Electric Drill
Drill Bits: $\frac{1}{4}$ ", $\frac{1}{8}$ "
Scribe
Pop Rivet Gun

1. Before beginning this operation, the rear splash panel should be properly aligned with the engine cover (Operation 34, Step 5).
2. Position the engine cover holddown latch on the top of the rear splash panel, 2" from the forward edge of the splash panel and $\frac{1}{8}$ " from the side of the engine cover (Fig. 35.1). Using the latch as a template, scribe the two mounting holes of the latch onto the splash panel.
3. Drill the mounting holes scribed in Step 2, using a $\frac{1}{4}$ " drill bit. Pop rivet the latch to the splash panel, using $\frac{3}{16}$ " x $\frac{5}{8}$ " pop rivets.
4. Position the engine cover holddown catch on the side of the engine cover, so that the edge below the mounting holes is $3 \frac{1}{4}$ inches, and the catch aligns with the hook of the latch. Using the catch as a template scribe the 2 mounting holes onto the engine cover, and drill using a $\frac{1}{4}$ " drill bit. Pot rivet the catch to the engine cover with $\frac{3}{16}$ " x $\frac{5}{8}$ " pop rivet.
5. Position the back-up light on the driver side of the rear splash panel in front of the engine cover and to the outside of the overrider. Using the light mounting base as a template, scribe the two mounting holes onto the splash panel.
6. Drill out the mounting holes scribed in Step 5, using $\frac{1}{4}$ " drill bit. Pop rivet the back-up light to the splash panel, using $\frac{3}{16}$ " x $\frac{5}{8}$ " pop rivets.
7. Directly behind the back-up light base, drill a $\frac{1}{8}$ " hole to allow for wiring connections at a later step.

ENGINE COVER CLASPS. FIG. 351

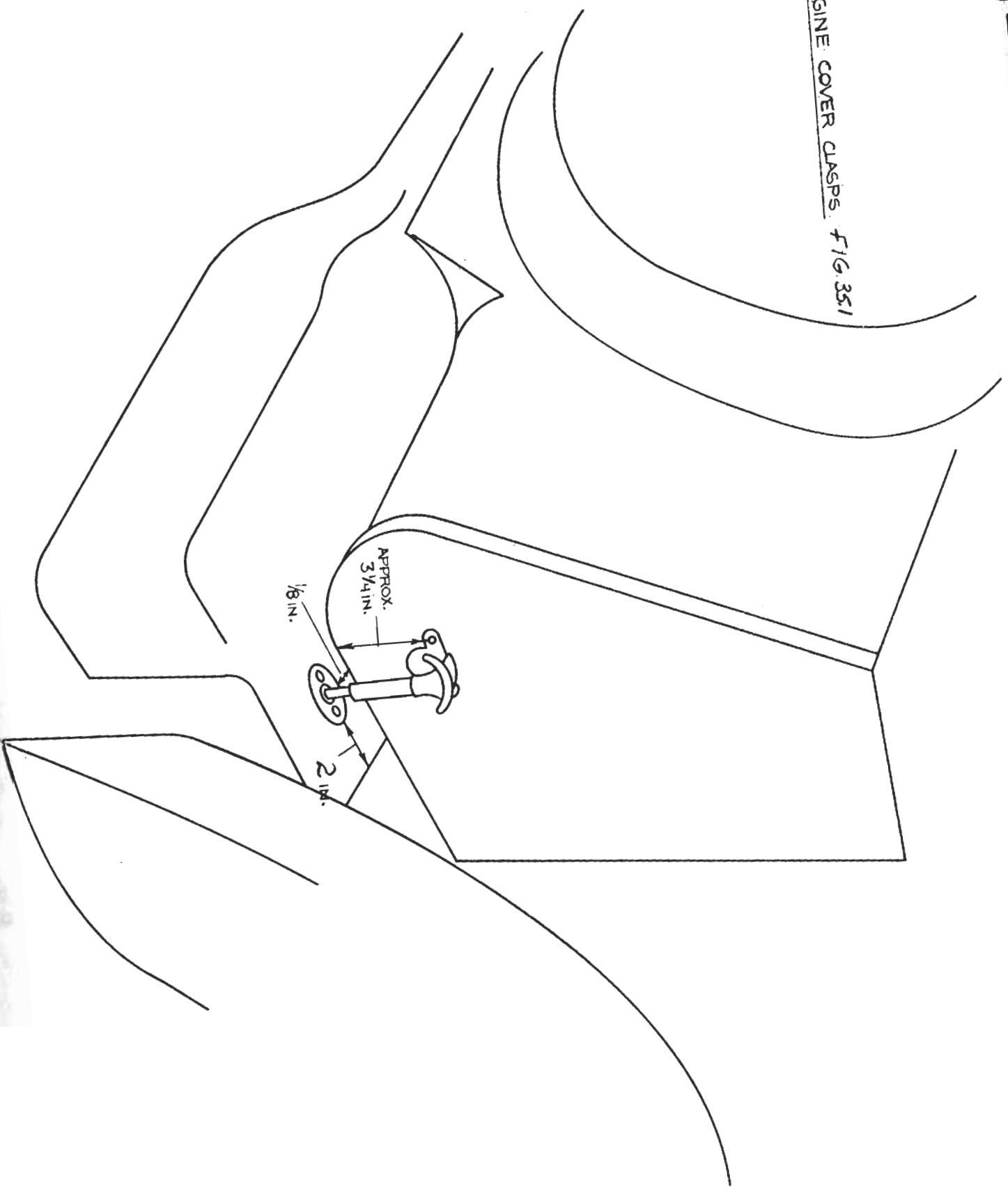

36. GAS TANK INSTALLATION AND BRAKE FLUID RESERVOIR

We suggest using a 1961-1967 VW fuel tank for ease of installation. The fuel tank spout must be altered for hood clearance. We recommend taking the fuel tank to a welding shop or radiator repair shop, as this welding procedure could be dangerous.

1. Before welding or cutting the gas tank fill neck, fill the tank completely with hot water and detergent and shake the tank well. Drain and repeat this procedure.
2. With the water and detergent still in the tank, cut off the filler spout flush with the main section of the gas tank.
3. With the cap still on the filler spout, measure down $\frac{1}{4}$ " from the bottom edge of the filler cap and scribe a line on the filler spout.
4. Cut the filler spout off at the scribed line with a hack saw.
5. Weld the filler spout back into place on the gas tank, and drain the gas tank of water.
6. Set the fuel tank into the isolation insert.
7. Using a 5/16" drill bit, drill two holes in the main body on either side of the gas tank, $\frac{1}{2}$ " outside the gas tank flange. Do not drill through the gas tank flange, as this will cause leaking.
8. Using the large fender washers supplied in the Bolt Kit, and the 5/16" PAL nuts, secure the gas tank in place. The washers should overlap the flange of the gas tank, holding it in place.
9. Connect the rubber gas line on the bottom of the tank to the top of the I-beam, and secure the line with a hose clamp.
10. Mount the brake fluid reservoir on the driver side, front bulkhead of the main body section, directly above the master cylinder. Use $\frac{1}{2}$ " aluminum strapping or banding wire and two sheet metal screws to secure the reservoir. Connect the hoses to the master cylinder and fill the reservoir with brake fluid. The brakes will have to be bled before the car can be driven.

37. WIRING COMPLETION

1. Attach the voltage regulator from the original VW on the fan shroud at the passenger side, using the bolts from the VW assembly.
2. Position the battery in the original mounting location, on the passenger side of the floor pan. The battery will be permanently secured when the seats are installed.
3. Complete the wiring connections according to the wiring diagrams included with the harness. Connections include: master cylinder, gas tank sending unit, turn signal cancellor, fog light, and battery; and rear engine connections including generator wires, oil sending unit, solenoid, back-up light, license plate light, and voltage regulator.
4. Drill a 1/8" hole in the firewall and in the lower front bulkhead, on the driver side of the main body section. Connect the threaded end of the speedometer cable to the speedometer. Run the cable through the 1/8" hole in the firewall and the bulkhead, and insert the cable in the front wheel where the original speedometer cable was removed.

38 INTERIOR CARPETING

Fiberfab Parts Required:

M527 Upholstery Kit
MX194 Contact Cement
M555 Bolt Kit

Tools and Materials Required:

Scissors
Glue Brush
Electric Drill
Drill Bit: 1/8"
Screwdriver

1. Consult the pattern diagram, Fig. 38.1 and 38.2, to identify each carpet piece.
2. Spread a thin layer of contact cement on each piece of carpet and on the area of the main body on which it fits.
3. The carpet pieces are installed in the following order: Wheel well covers, rear side panels, rear deck floor, back (Fig. 38.1); tunnel end, tunnel section, driver's floor, passenger floor, driver side panel, passenger side panel (Fig. 38.4). Note: The side panels should be installed after the striker plates have been attached (Operation 40).
4. Drill through the side panels (on both sides) and into the main body section around the upper edge, at 10 evenly spaced points. Use a 1/8" drill bit. Insert trim screws into the holes to secure the panels to the body.

REAR INTERIOR PICES. FIG. 38.1

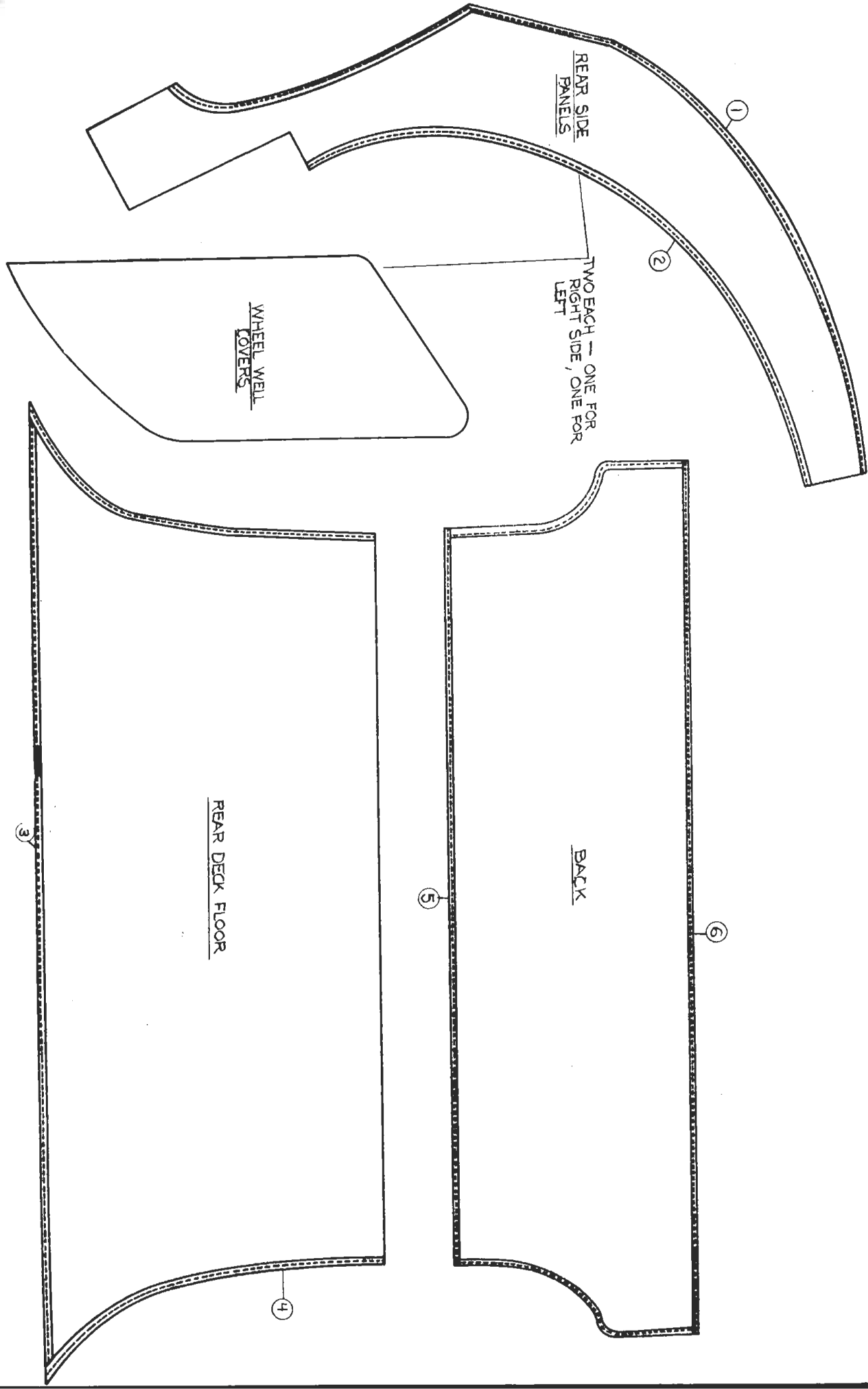

INTERIOR (FRONT) FIG. 38.2

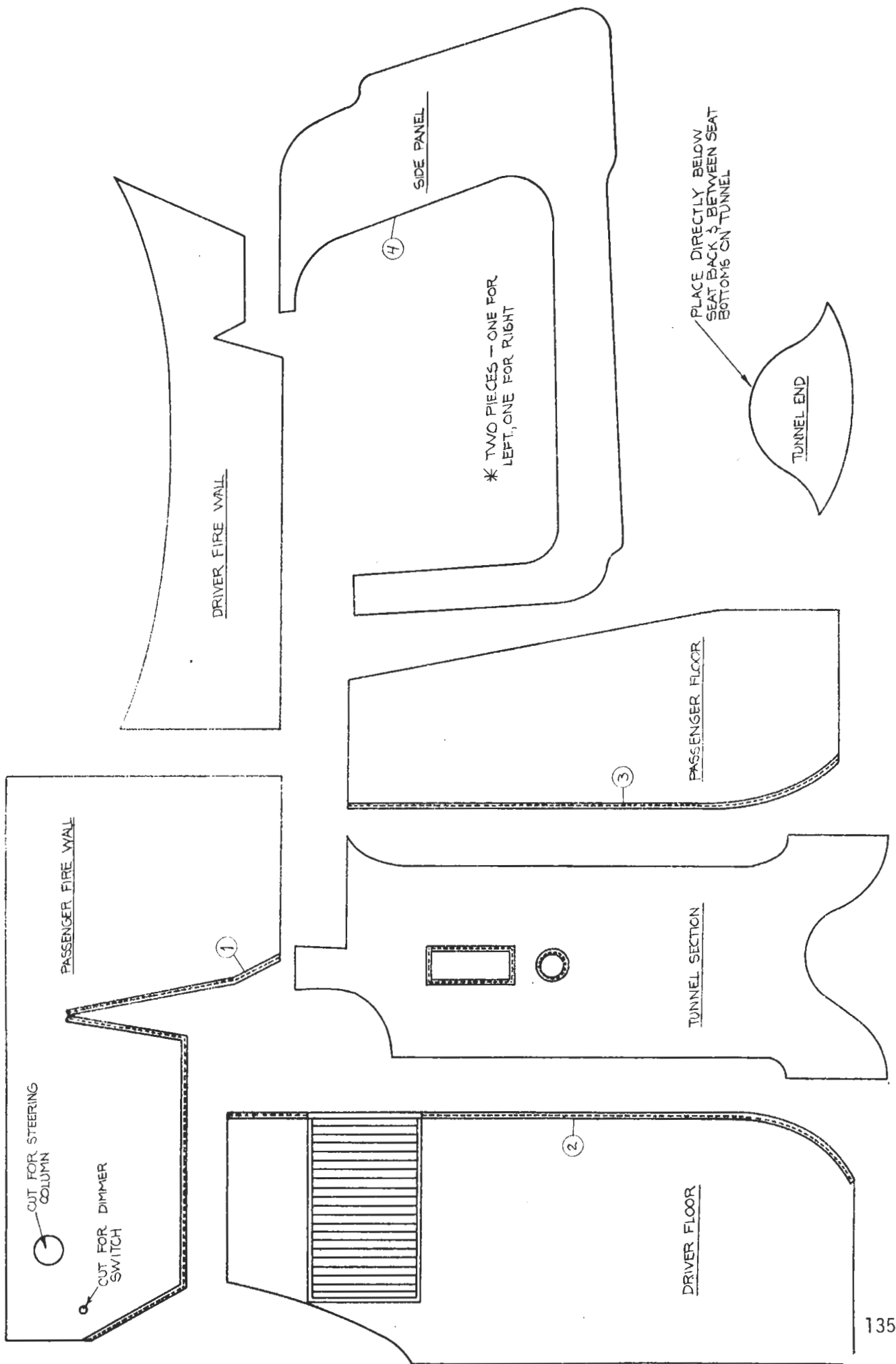

REAR INTERIOR FIG. 39.3

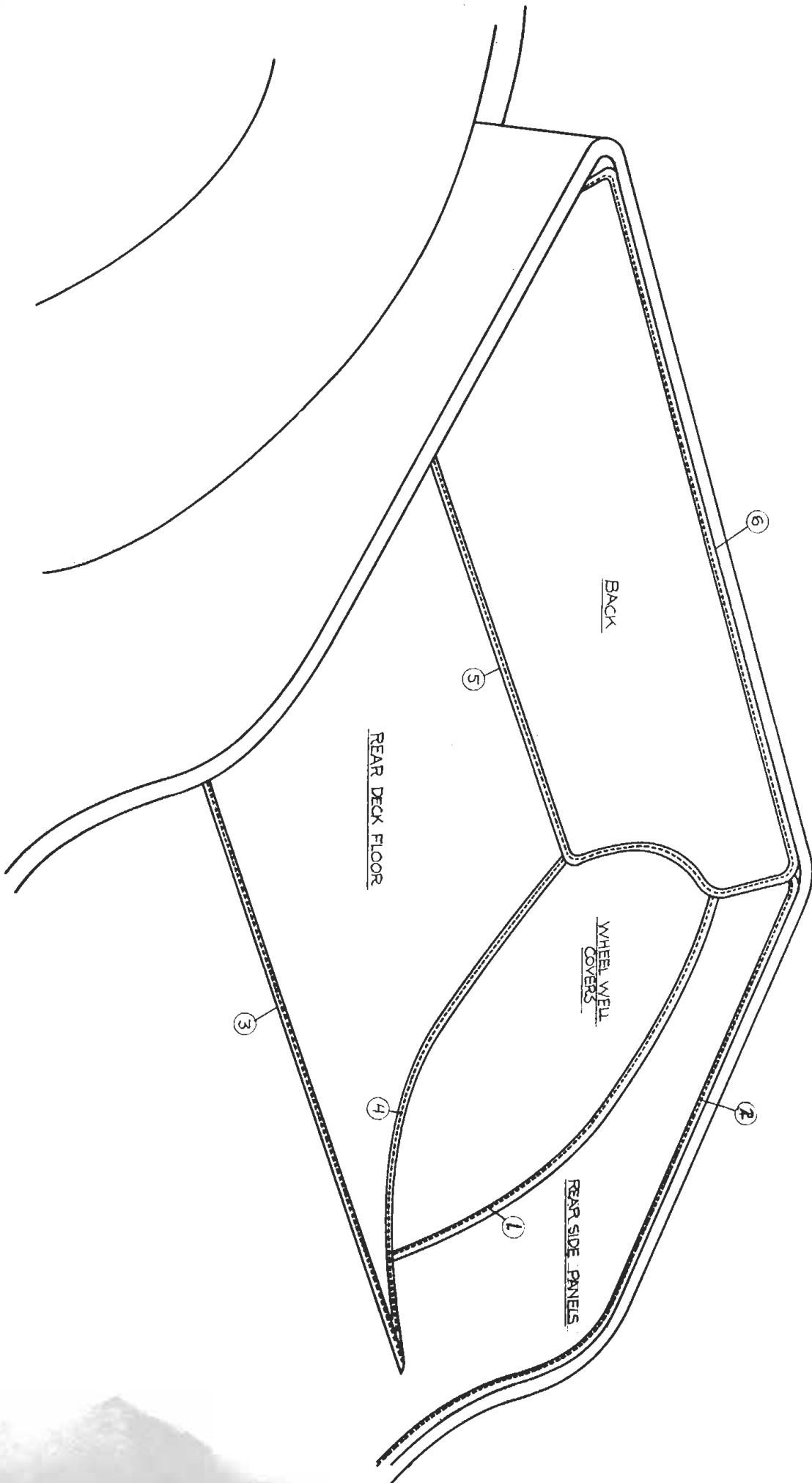

FRONT INTERIOR 'FIG 38,4

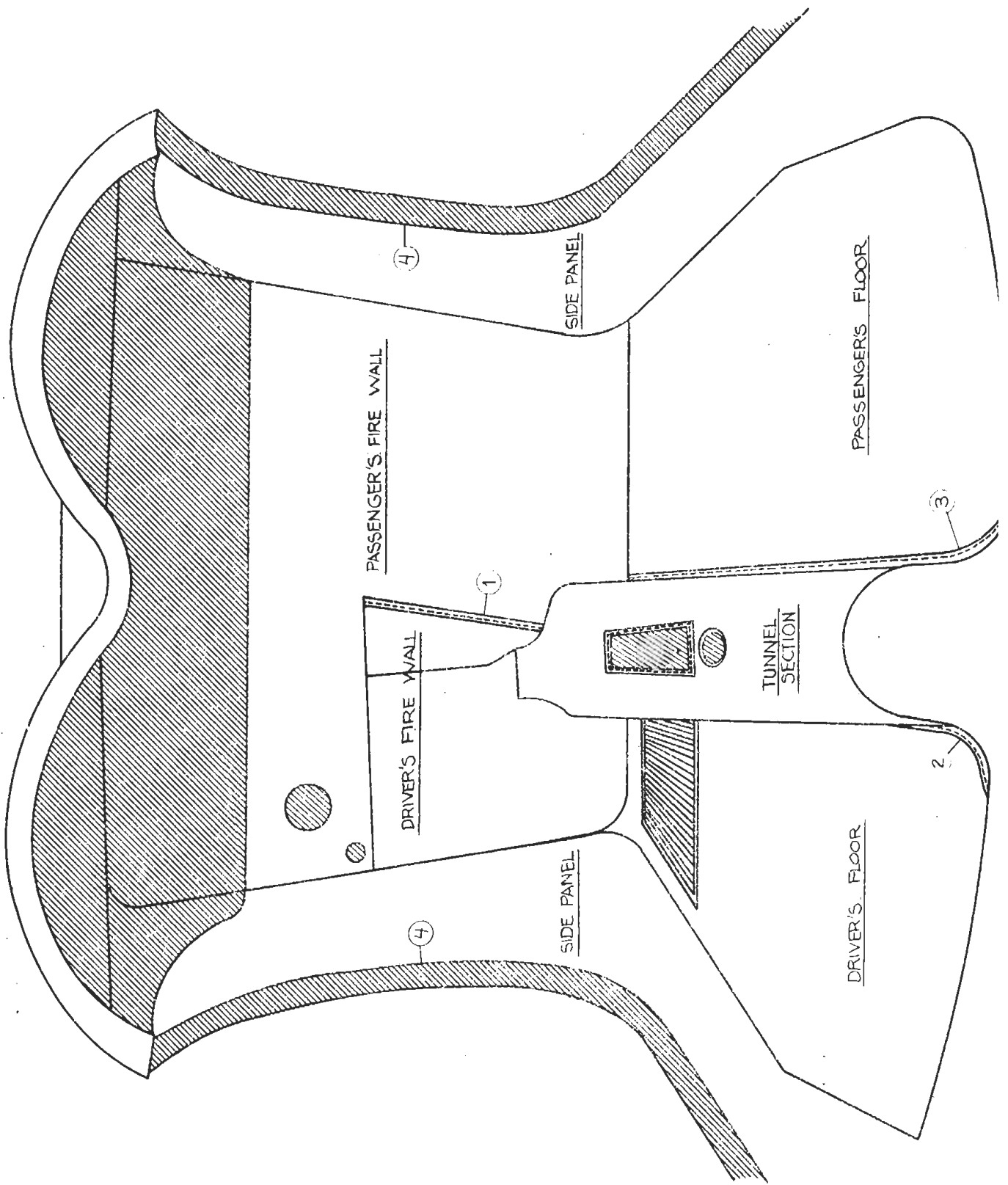

39. SEAT BOXES, SEAT BACKS AND HEATER TUBES

Fiberfab Parts Required:

M500	Seat Boxes
M527	Seats (Upholstery Kit)
M555	Bolt Kit
M563	Seat Back Hinge
X180	Heater Tubes

Tools and Materials Required:

Electric Drill
Drill Bits: 5/16", 1/8"
Hole Saw: 2"
Wrench
Screwdriver

1. Position the seat boxes on the floor pan, with the curved edge of each box facing the center tunnel (Fig. 39.1).
2. Using a 5/16" drill bit, drill through the base of the seat box and the floor pan at the 4 corners. Secure the seat box to the floor pan using 5/16"-18 x 1 1/2" step bolts.
3. Position the upholstered seat back on the main body mounting flange over the rear cross bracing of the chassis.
4. Using a 1/8" drill bit, drill a hole in each side of the main body, as illustrated in Fig. 39.1. Using trim screws, bolt the hinge to the body through the hole drilled above.
5. Using the hinge as a template, scribe a mounting hole onto the back of the seat and drill, using a 1/8" drill bit. Bolt the hinge to the back of the seat using trim screws.
6. Cut the heater tube (supplied with the MiGi II) into two equal lengths.
7. Using a 2" hole saw drill a hole in the front panel of each seat box. Drill a 2" hole in the main body section directly behind the hole drilled in the seat box. (Fig. 39.2).
8. Connect the heater hoses to the heat boxes on the engine, using the original clamps or a heat resistant duct tape. Insert the tubes through the 2" holes in the main body and in the seat boxes, so that the heater tubes extend to the driving compartment of the car. (Fig. 39.2).

9. Cut the ends of the heater tubes flush with the front panel of the seat box.
10. Place the battery inside the passenger seat box. Place the seat bottoms onto the seat boxes, and underneath the seat backs. **Note** : It is advisable to glue or nail a 1" x 1" x 5" piece of wood onto the bottom of each seat, to fit against the front edge of the seat box. This will act as brace, preventing the seats from sliding forward.

SEAT BACK & SEAT BOXES FIG. 39.1

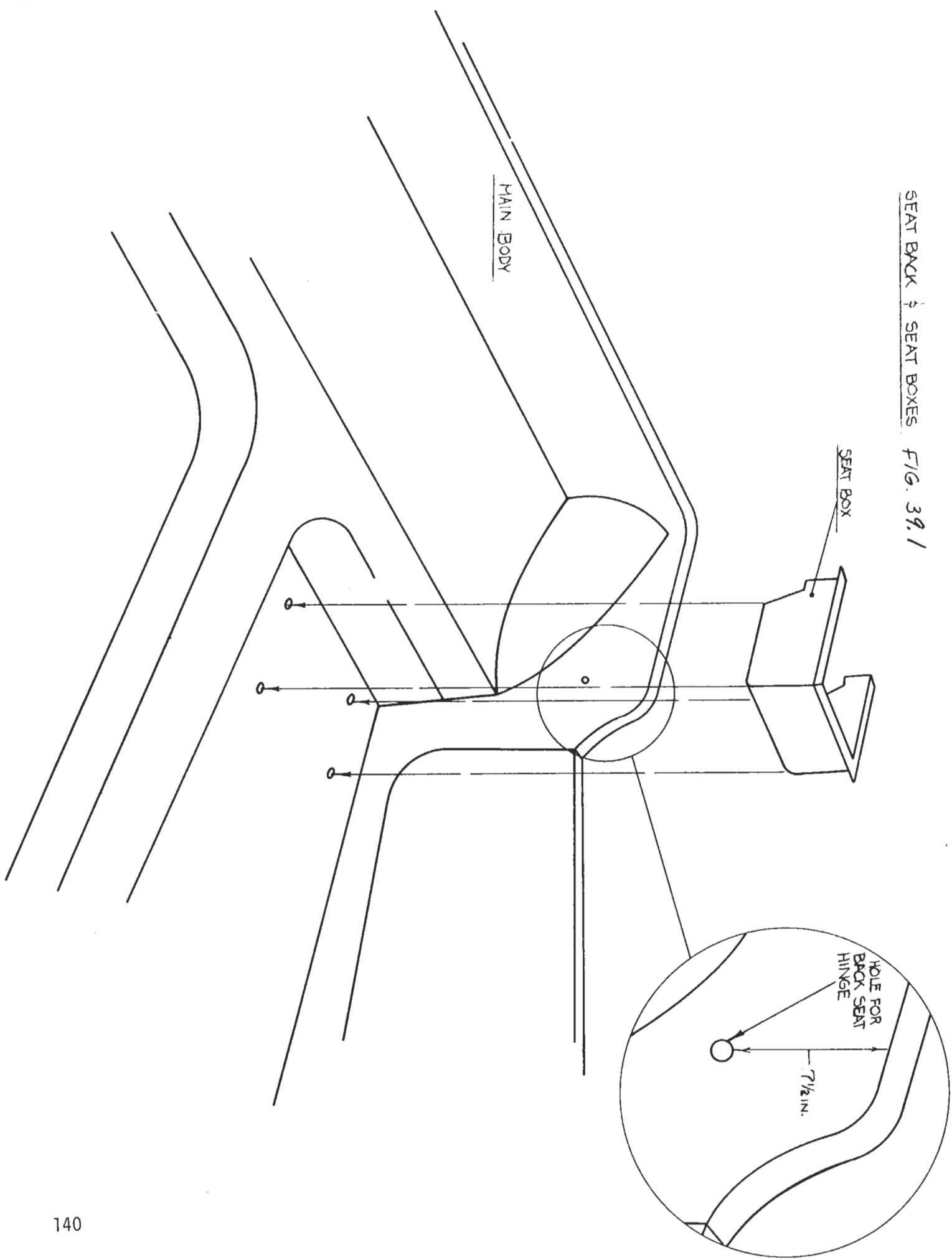

HEATER HOSE INSTALLATION FIG. 39.2

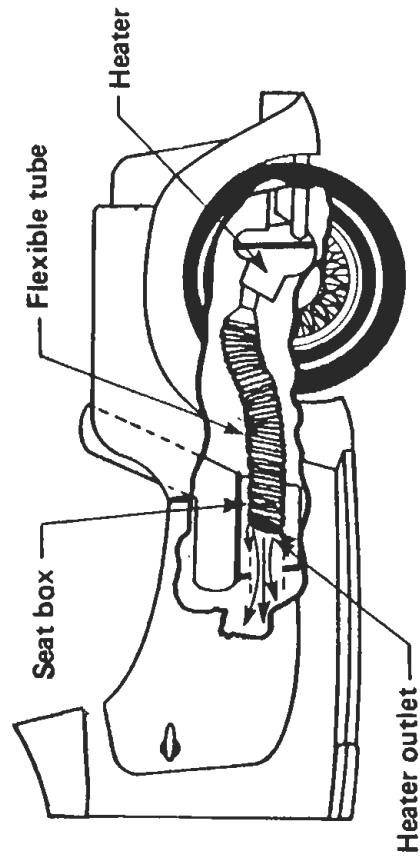

40. STRIKER PLATES

Fiberfab Parts Required:

M519 Latch Striker Plates
M555 Bolt Kit

Electric Drill
Drill Bit: 5/16"
Screwdriver

1. Position the striker plate against the main body section door jam. The inner edge of the striker plate should align with the inner edge of the door jam, and the striker plate catches should line up with latch tab on the door. (Fig 40.1)
2. Using a 5/16" drill bit, drill through both the striker plate and the door jam of the upper and lower corners of the plate.
3. Secure the striker plate to the door jam, using 1/4-20 x 1 1/2" bolts.
4. Close the door and adjust the striker plate to the left or right as necessary. Note: The interior side panels should now be installed, according the Operation 38, Steps 2 and 4.

STRIKER PLATE 40.1

MAIN BODY

STRIKER PLATE

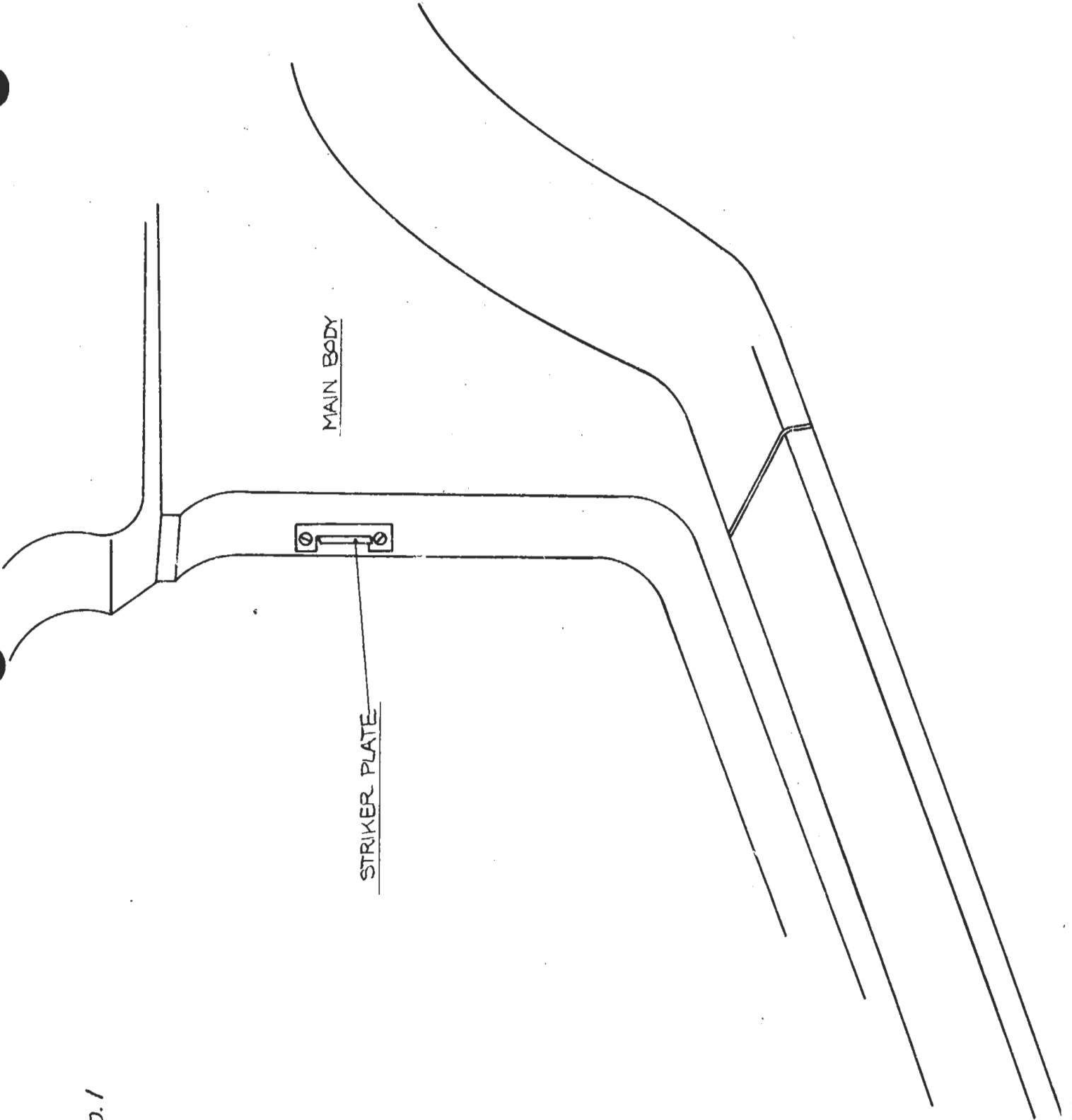

41. MlGf II COMPLETION

Fiberfab Parts Required:

X124	Air Cleaner
M559	Wheel Covers
MX195	Undercoating

1. Air Cleaner:

The MiGi II builder kit includes a new low profile air cleaner, needed for engine cover clearance. Position the air cleaner on top of the carburetor, and tighten the clamp on the carburetor rim with the adjusted screw.

2. Wire Wheel Covers:

The MiGi II uses stock 15" VW wheels and tires. Use a rubber mallet or hammer along the outside edge of the wheel cover, to tap the wheel cover into the wheel rim.

3. Undercoat:

Finally, spray undercoat under the front and rear fenders to reduce road noise.

ACCESSORY SUPPLEMENT

CHROME GRILL INSTALLATION

The chrome grill shell is a reproduction of the original M.G. Grill made of brass and chrome plated. Because it is the original, it must be cut at the lower corners to allow it to fit over the Migi Grill Bib.

Attached are two templates for this procedure. They are marked Driver Side and Passenger Side - See Pages 5 & 6. This is important because each side is cut differently.

Cut the template on the line marked CUT along line. See Fig. 2, page 3. The pins inside grill shell should also be removed. Heat the pins, if any, with a torch just enough to melt the solder.

A fine tooth file will clean the edges of the burrs and will smooth it. See fig. 3, page 3.

Fender welt can also be installed if desired.

FIBERGLASS GRILL SHELL INSTALLATION

In order for the chrome grill shell to fit over the fiberglass grill shell some cutting must be done. Refer to black lines on Fig. 4, page 4, for cutting of fiberglass grill shell. Fig. 5, page 4, shows the grill after being cut. Fig. 6, page 4, shows how the grill should look when completed.

CHROME GRILL SHELL INSTALLATION

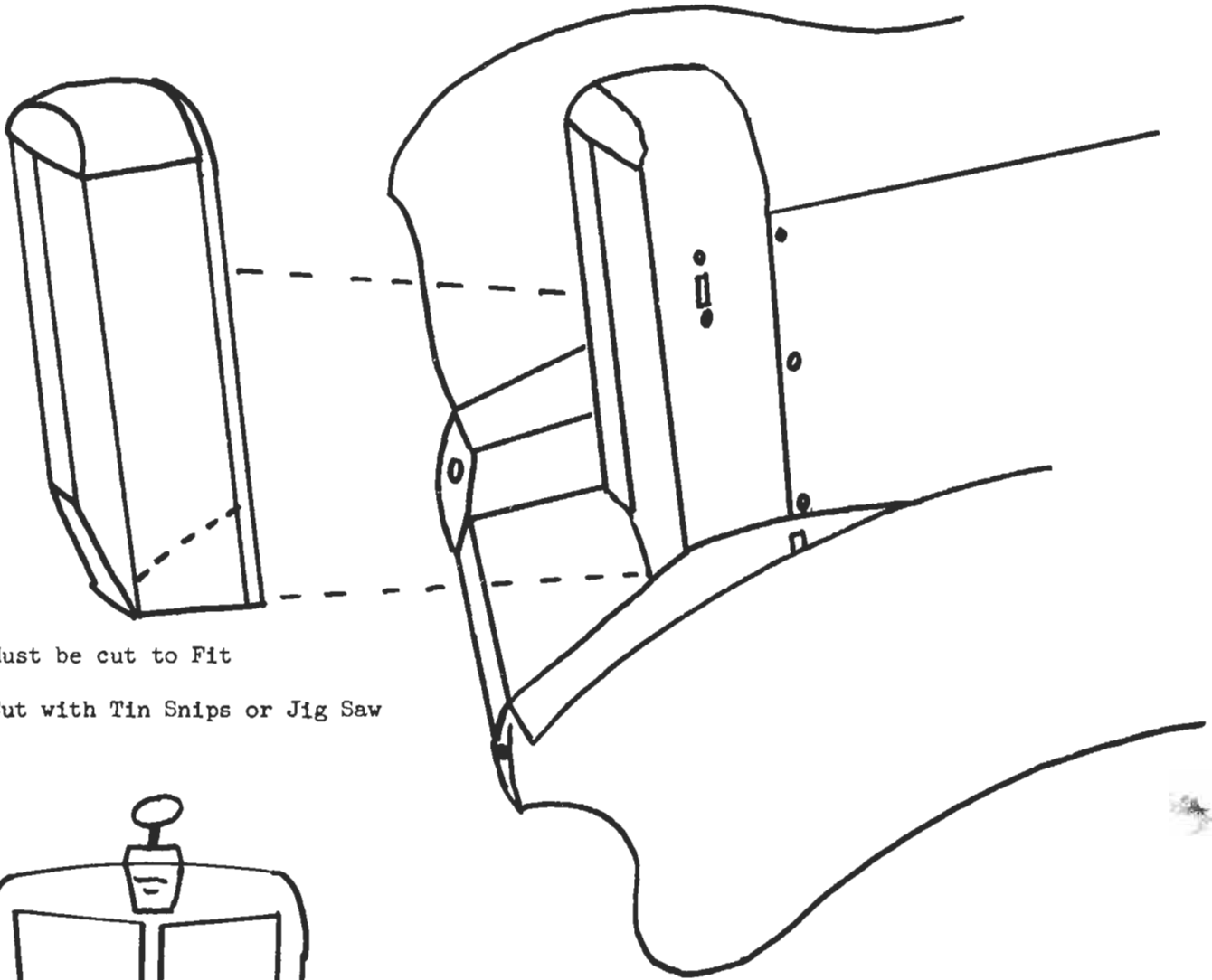

Must be cut to Fit

Cut with Tin Snips or Jig Saw

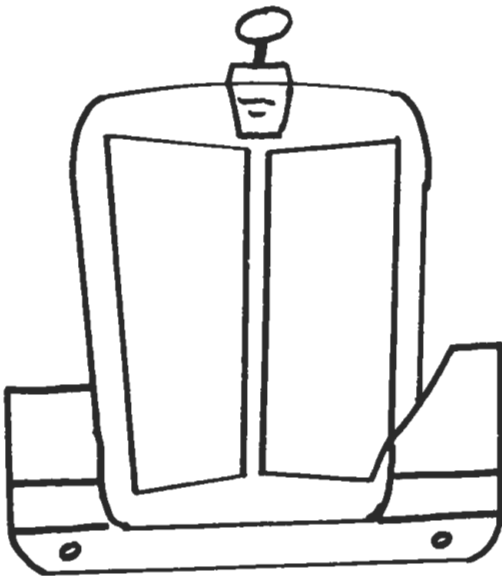



FIG 1

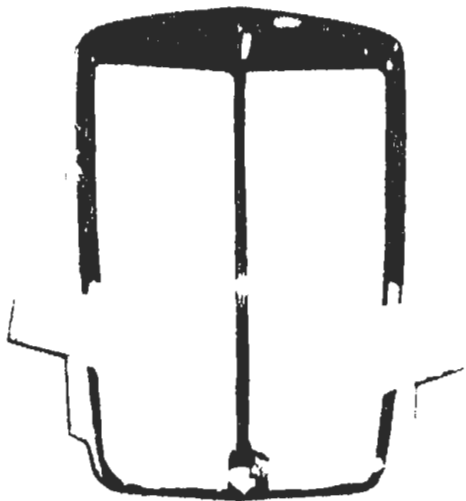

FIG 2

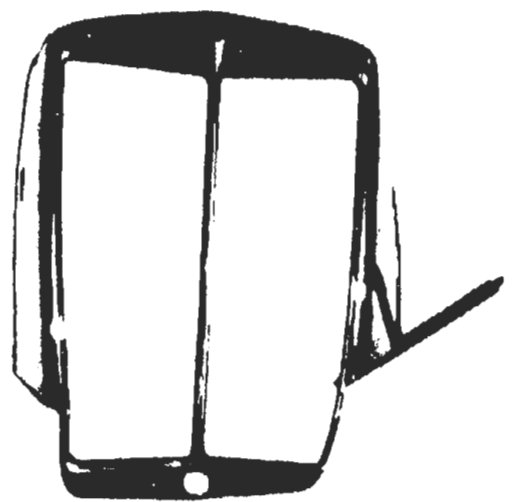

FIG 3



FIG 4

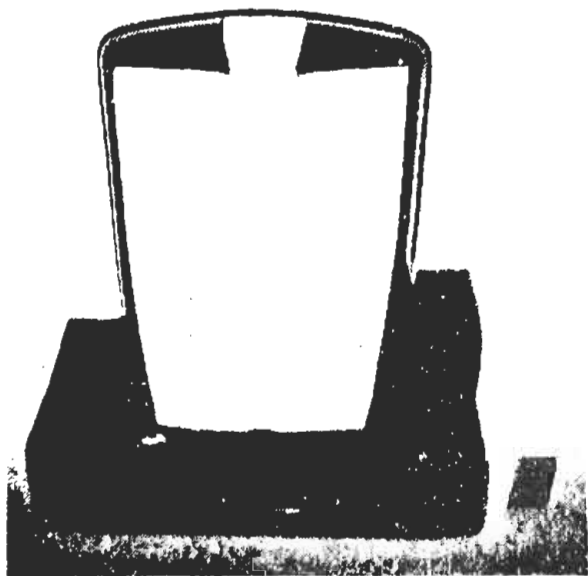

FIG 5

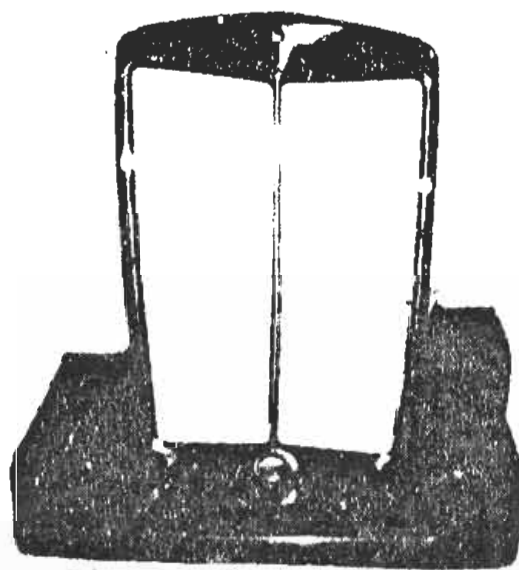

FIG 6